



HARTNER

Precision Cutting Tools

THREADING TOOLS

NEW COMPLETE PROGRAMME
FOR UNIVERSAL THREAD PRODUCTION



ISO code

P	Steel, high-alloyed steel
M	Stainless steel
K	Grey cast iron, spheroidal cast iron and malleable cast iron
N	Aluminium and other non-ferrous metals
S	Special, super and titanium alloys
H	Hardened steel and chilled cast iron

Pictograms

Tool material	HSS-E HSS-E-PM
	High-speed steel
Surface	
	bright steam tempered nitrided TiAlN+WC/C TiCN TiN
Type	N TG 100 GG TG 100 T TG 100 U TG 300 T W
Ø tolerance	2B 2BX 4HX 6GX 6HX Class 1/ OH Class 2/ RH ISO2/6H OH2
Standard	DIN 371 ~DIN 371 DIN 371/376 ~DIN 371/376 DIN 374 ~DIN 374 DIN 2189 DIN 5156 JISB 4430
	to Hartner standard
Cutting direction	
	right
Shank form	
	straight shank
Form	B C
Hole type	
	Through holes Blind holes Through holes and blind holes
Internal cooling	
	with IC without IC





TG 100 U
▼ BASICLINE TAPS

basicline



TG 100 T
▼ TOPLINE TAPS

topline



TG 100 AL
▼ TAPS
FOR ALUMINIUM



TG 100 GG
▼ TAPS
FOR CAST MATERIALS



TG 300 T
▼ HIGH-PERFORMANCE TAPS
FOR CAST MATERIALS



TAPS FOR MANUAL MACHINING

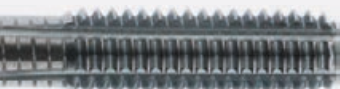

FLUTELESS TAPS



JIS TAPS AND FLUTELESS TAPS

TAPS AND FLUTELESS TAPS

▼ ACCORDING TO DIN STANDARD

										
Hole type			HSS-E				HSS-E-PM			
Tool material			HSS-E				HSS-E-PM			
Type/form			TG 100 U/B	TG 100 U/B	TG 100 T/B	TG 100 T/B	TG 100 U/C	TG 100 U/C	TG 100 U/C	TG 100 T/C
Surface			○	Ⓣ	ⓧ	ⓧ	○	Ⓣ	Ⓣ	ⓧ
			<u>basic</u> line	<u>basic</u> line	<u>top</u> line	<u>top</u> line	<u>basic</u> line	<u>basic</u> line	<u>basic</u> line	<u>top</u> line
										
			Article no. Ø range Page							
M	ISO 2 6H	DIN 371	80700 M2 - M10 Page 22	80710 M2 - M10 Page 24		80808 M3 - M20 Page 29	80730 M2 - M10 Page 21	80740 M2 - M10 Page 25		
	6HX				80800 M2 - M10 Page 27				80745 M3 - M20 Page 26	80830 M2 - M10 Page 30
	6GX				80805 M2 - M10 Page 28					80835 M2 - M10 Page 31
	ISO 2 6H	DIN 376	80700 M12 - M36 Page 22	80710 M12 - M24 Page 24			80730 M12 - M36 Page 21	80740 M12 - M24 Page 25		
	6HX				80800 M12 - M30 Page 25					80830 M12 - M30 Page 30
	6GX				80805 M12 - M30 Page 26					80835 M12 - M30 Page 31
MF	ISO 2 6H	DIN 374	80701 M4x0,5 - M42x1,5 Page 39	80711 M5x0,5 - M24x1,5 Page 41		80809 M8x1 - M24x1,5 Page 44	80731 M4x0,5 - M30x2 Page 40	80741 M5x0,5 - M24x2 Page 42		
	6HX				80801 M3x0,35 - M36x2 Page 43					80831 M6x0,75 - M24x1,5 Page 45
UNC	2B	~ DIN 371	80702 4-40 - 3/8-16 Page 51	80712 4-40 - 3/8-16 Page 53	80802 4-40 - 3/8-16 Page 55		80732 2-56 - 3/8-16 Page 42	80742 6-32 - 3/8-16 Page 54		80832 4-40 - 3/8-16 Page 46
	2B	~ DIN 376	80702 7/16-14 - 1-8 Page 51	80712 7/16-14 - 1-8 Page 53	80802 7/16-14 - 1-8 Page 55		80732 7/16-14 - 7/8-9 Page 52	80742 7/16-14 - 1-8 Page 44		80832 7/16-14 - 7/8-9 Page 56
UNF	2B	~ DIN 374	80703 4-48 - 1-12 Page 58	80713 4-48 - 1-12 Page 60	80803 4-48 - 1-12 Page 62		80733 3-56 - 1-12 Page 59	80743 6-40 - 7/8-14 Page 61		80833 10-32 - 1-12 Page 63
G	-	DIN 5156	80704 G1/8 - G2 Page 65	80714 G1/16 - G7/8 Page 67	80804 G1/8 - G1 Page 69		80734 G1/16 - G2 Page 66	80744 G1/8 - G1 Page 68		80834 G1/16 - G1 Page 70











○ bright ● steam tempered Ⓣ TiN ⓧ TiAlN-X+WC/C ● nitrided Ⓢ TiCN

HSS-E-PM			HSS-E				HSS-E-PM	HSS-E	HSS-E-PM
TG 100 T/C	TG 100 T/E	TG 100 T/C	TG 100 AL/B	TG 100 AL/C	TG 100 GG/C	TG 300 T/C	N/C	T/C	
X	X	X	○	○	●	●	T	C	
top line	top line	top line					basic line	top line	
									
Article no. Ø range Page						Article no. Ø range Page			
80806 M3 - M20 Page 32	80810 M2 - M30 Page 33	80782 M3 - M20 Page 34	80760 M2 - M10 Page 35	80761 M1,6 - M10 Page 30					
					80750 M3 - M10 Page 37	80850 M5 - M10 Page 38	80900 M3 - M10 Page 62	80920 M1 - M10 Page 63	
								80925 M2 - M10 Page 76	
			80760 M12 - M22 Page 29	80761 M12 - M24 Page 36					
					80750 M12 - M30 Page 31	80850 M12 - M39 Page 32	80900 M12 - M39 Page 74	80920 M12 - M20 Page 75	
								80925 M12 - M20 Page 64	
80807 M8x1 - M24x1,5 Page 46	80811 M6x0,75 - M24x1,5 Page 47	80783 M8x0,75 - M20x1,5 Page 48							
					80751 M4x0,5 - M30x1,5 Page 49	80851 M6x0,75 - M16x1,5 Page 50	80901 M6x0,75 - M24x1,5 Page 77	80921 M8x1 - M20x1,5 Page 78	
					80752 4-40 - 3/8-16 Page 57		80902* 4-40 - 3/8-16 Page 79	80922 4-40 - 3/8-10 Page 80	
					80752 7/16-14 - 1-8 Page 57		80902* 7/16-14 - 3/4-10 Page 79	80922 7/16-14 - 3/4-10 Page 80	
					80753 4-48 - 1-12 Page 64		80903* 4-48 - 3/4-16 Page 81	80923 4-48 - 3/4-16 Page 82	
	80812 G1/16 - G1 Page 71	80784 G1/16 - G1 Page 72			80754 G1/16 - G2 Page 73		80904 G1/16 - G3/4 Page 83	80924 G1/8 - G1/2 Page 84	

*Tolerance zone 2BX

TAPS AND FLUTELESS TAPS

▼ ACCORDING TO JIS STANDARD





Thread type	Tolerance zone	Dimensions to DIN 2184-1	Hole type				Hole type
							
			Tool material				Tool material
			Type/form				Type/form
			Surface				Surface
			_basic_line				
			_top_line				
							
							
							
							
			Article no. Ø range Page				Article no. Ø range Page
M	Class 1 OH	JIS B 4430	80780 M2 - M20 Page 73	80880 M2 - M20 Page 75	80790 M2 - M20 Page 74	80890 M2 - M30 Page 76	
	Class 2 RH						80980 M4 - M20 Page 81
MF	Class 1 OH	JIS B 4430	80781 M6x0.75 - M20x1.5 Page 77	80881 M6x0.75 - M20x1.5 Page 79	80791 M6x0.75 - M20x1.5 Page 78	80891 M4x0.5 - M22x1.5 Page 80	
	Class 2 RH						80981 M6x0.75 - M20x1.5 Page 82

 TiN

 TiAlN-X+WC/C



TAPS FOR MANUAL MACHINING

Hole type			
Tool material	HSS-E	HSS-E	
Type/form	U/B	U/B	
Surface			
			
Thread type	Tolerance zone	Dimensions to DIN 2184-1	Article no. Ø range Page
M	Class 1 OH	JIS B 4430	80990 M2 - M20 Page 95
	Class 2 RH		80991 M2 - M20 Page 96
			80992 M4 - M20 Page 97

 steam tempered

basic line



TG 100 U

- ▼ universal tap for machining general, high-tensile and stainless steels
- ▼ highest efficiency thanks to its remarkable price/performance ratio for smaller and mid-size productions
- ▼ NEW: with TiN coating

top line

TG 100 T

- high-performance tap for demanding machining tasks in general, high-tensile and stainless steels
- optimised cutting edge geometry for optimal chip evacuation
- ultra-smooth multi-layer coating consisting of a base of TiAlN with a hardness of 3000 HV and a top coating of WC/C (Tungsten carbide/carbon layer) to reduce the friction value and the tendency towards cold welding. The result is improved chip flow and an effective wear resistance.
- maximum tool life with excellent thread quality

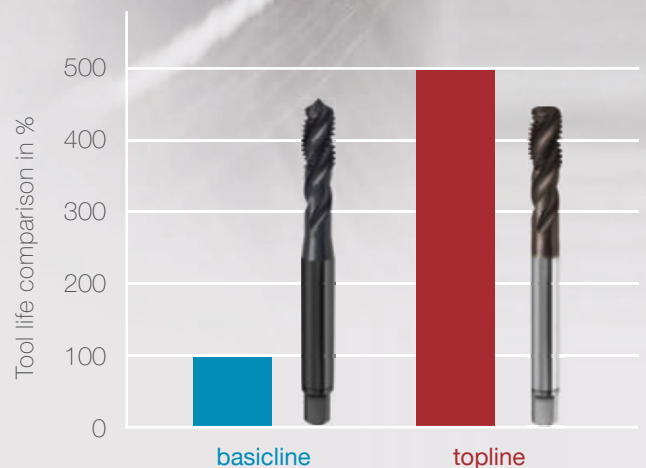

Test material 1,4301

THE POWER PERFORMERS

TG 100 GG

- ▼ tap for the machining of cast materials and short-chipping non-ferrous metals
- ▼ cast iron geometry with nitrided surface finish for economical machining
- ▼ a remarkable price-performance-ratio for small batch sizes



TG 300 T

- ▼ high-performance tap with a wide application range for demanding machining tasks in all cast materials, general and high-tensile steels and aluminium cast alloys
- ▼ straight-fluted cutting edge geometry for increased rigidity and to produce short chips
- ▼ the combination of the HSS-E-PM tool material, TiCN coating and internal cooling ensures a high wear resistance and provides a process reliable maximum tool life

FORMING

basic_{line}

FLUTELESS TAPS

- ▼ fluteless taps for chip-free threading of through and blind holes
- ▼ oil grooves ensure optimal coolant supply
- ▼ high wear resistance in most materials thanks to TiN coating and special geometry
- ▼ the forming process increases the tensile strength in the thread area of the component

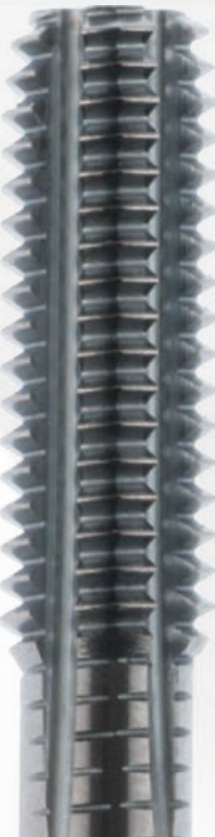

top_{line}

HIGH-PERFORMANCE FLUTELESS TAPS

- ▼ thanks to the modified polygon form the torque is reduced by up to 30 %
- ▼ increased wear resistance thanks to the application of a new powder metallurgical base material
- ▼ improved lubricating effect thanks to the optimised lubrication grooves
- ▼ the special surface finish treatment in combination with the TiCN coating ensures increased wear resistance

THE SPECIALIST FOR ALUMINIUM AND ALUMINIUM ALLOYS



TG 100 AL

- ▼ tap for aluminium, aluminium alloys, non-ferrous metals and plastics
- ▼ special geometry for the machining of soft materials
- ▼ bright surface



SOLID CARBIDE THREAD MILLING CUTTERS



Further information can be found in the brochure Thread milling cutters.

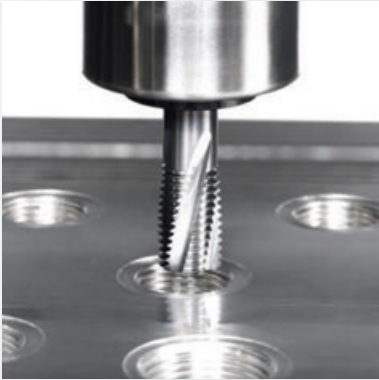







P	M	K	N	S	H	Standard	Type	Tool material	Surface	Form	Tolerance	Hole type	d1	Article no.	Page
---	---	---	---	---	---	----------	------	---------------	---------	------	-----------	-----------	----	-------------	------

Taps for ISO metric threads





















	DIN 371/376	TG 100 U	HSS-E		B	ISO2/6H			basic line
								M2 - M36	80700 22
	DIN 371/376	TG 100 U	HSS-E		C	ISO2/6H			basic line
								M2 - M36	80730 23
	DIN 371	TG 100 U	HSS-E	T	B	ISO2/6H			basic line
								M3 - M24	80710 24
	DIN 371	TG 100 U	HSS-E	T	C	ISO2/6H			basic line
								M2 - M24	80740 25
	WN	TG 100 U	HSS-E	T	C	6HX			basic line
								M3 - M20	80745 26
	DIN 371/376	TG 100 T	HSS-E	X	B	6HX			top line
								M2 - M30	80800 27
	DIN 371	TG 100 T	HSS-E	X	B	6GX			top line
								M2 - M30	80805 28
	DIN 371	TG 100 T	HSS-E-PM	X	B	6HX			top line
								M3 - M20	80808 29
	DIN 371/376	TG 100 T	HSS-E	X	C	6HX			top line
								M2 - M30	80830 30
	DIN 371	TG 100 T	HSS-E	X	C	6GX			top line
								M2 - M30	80835 31
	DIN 371	TG 100 T	HSS-E-PM	X	C	6HX			top line
								M3 - M20	80806 32
	DIN 371	TG 100 T	HSS-E	X	E	6HX			top line
								M2 - M30	80810 33
	WN	TG 100 T	HSS-E	X	C	6HX			top line
								M3 - M20	80782 34
	DIN 371	W	HSS-E		B	ISO2/6H			
								M2 - M22	80760 35

P	M	K	N	S	H	Standard	Type	Tool material	Surface	Form	Tolerance	Hole type	d1	Article no.	Page
---	---	---	---	---	---	----------	------	---------------	---------	------	-----------	-----------	----	-------------	------

Taps for ISO metric threads







	DIN 371	W	HSS-E	○	C	ISO2/6H		M1,6 - M24	80761	36
	DIN 371/376	TG 100 GG	HSS-E	●	C	6HX		M3 - M30	80750	37
	DIN 371/376	TG 300 T	HSS-E HSS-E-PM	⊙	C	6HX		M5 - M39	80850	38

Taps for ISO metric fine threads





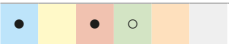





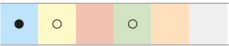

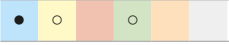

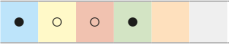

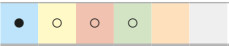
	DIN 374	TG 100 U	HSS-E	○	B	ISO2/6H		M4 x 0,5 - M42 x 1,5	basic line	80701	39
	DIN 374	TG 100 U	HSS-E	○	C	ISO2/6H		M4 x 0,5 - M30 x 2	basic line	80731	40
	DIN 374	TG 100 U	HSS-E	⊙	B	ISO2/6H		M5 x 0,5 - M24 x 1,5	basic line	80711	41
	DIN 374	TG 100 U	HSS-E	⊙	C	ISO2/6H		M5 x 0,5 - M24 x 2	basic line	80741	42
	DIN 374	TG 100 T	HSS-E	⊗	B	6HX		M3 x 0,35 - M36 x 2	top line	80801	43
	DIN 374	TG 100 T	HSS-E-PM	⊗	B	6HX		M8 x 1 - M24 x 1,5	top line	80809	44
	DIN 374	TG 100 T	HSS-E	⊗	C	6HX		M6 x 0,75 - M24 x 1,5	top line	80831	45
	DIN 374	TG 100 T	HSS-E-PM	⊗	C	6HX		M8 x 1 - M24 x 1,5	top line	80807	46
	DIN 374	TG 100 T	HSS-E	⊗	E	6HX		M6 x 0,75 - M24 x 1,5	top line	80811	47
	WN	TG 100 T	HSS-E	⊗	C	6HX		M8 x 0,75 - M20 x 1,5	top line	80783	48

P	M	K	N	S	H	Standard	Type	Tool material	Surface	Form	Tolerance	Hole type	d1	Article no.	Page
---	---	---	---	---	---	----------	------	---------------	---------	------	-----------	-----------	----	-------------	------







Taps for ISO metric fine threads

		DIN 374	TG 100 GG	HSS-E	●	C	6HX		M4 x 0,5 - M30 x 1,5	80751	49
		DIN 374	TG 300 T	HSS-E-PM	⊙	C	6HX		M6 x 0,75 - M16 x 1,5	80851	50

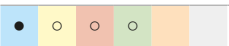
Taps for UNC threads

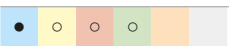

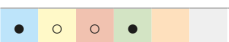





		~DIN 371/376	TG 100 U	HSS-E	●	B	2B		4 - 40 - 1 - 8	basic line	80702	51
		~DIN 371/376	TG 100 U	HSS-E	●	C	2B		2 - 56 - 7/8 - 9	basic line	80732	52
		~DIN 371	TG 100 U	HSS-E	⊙	B	2B		4 - 40 - 1 - 8	basic line	80712	53
		~DIN 371	TG 100 U	HSS-E	⊙	C	2B		6 - 32 - 1 - 8	basic line	80742	54
		~DIN 371/376	TG 100 T	HSS-E	⊗	B	2BX		4 - 40 - 1 - 8	top line	80802	55
		~DIN 371/376	TG 100 T	HSS-E	⊗	C	2BX		4 - 40 - 7/8 - 9	top line	80832	56
		~DIN 371/376	TG 100 GG	HSS-E	●	C	2B		4 - 40 - 1 - 8	basic line	80752	57

Taps for UNF threads











		~DIN 374	TG 100 U	HSS-E	●	B	2B		4 - 48 - 1 - 12	basic line	80703	58
		~DIN 374	TG 100 U	HSS-E	●	C	2B		3 - 56 - 1 - 12	basic line	80733	59
		~DIN 374	TG 100 U	HSS-E	⊙	B	2B		4 - 48 - 1 - 12	basic line	80713	60

P	M	K	N	S	H	Standard	Type	Tool material	Surface	Form	Tolerance	Hole type	d1	Article no.	Page
---	---	---	---	---	---	----------	------	---------------	---------	------	-----------	-----------	----	-------------	------

Taps for UNF threads







	~DIN 374	TG 100 U	HSS-E	T	C	2B		_basic line	6 - 40 - 7/8 - 14	80743	61
	~DIN 374	TG 100 T	HSS-E	X	B	2BX		-top line	4 - 48 - 1 - 12	80803	62
	~DIN 371/374	TG 100 T	HSS-E	X	C	2BX		-top line	10 - 32 - 1 - 12	80833	63
	~DIN 374	TG 100 GG	HSS-E	●	C	2B			4 - 48 - 1 - 12	80753	64

Taps for BSP threads





	DIN 5156	TG 100 U	HSS-E	●	B			_basic line	G1/8 - G2	80704	65
	DIN 5156	TG 100 U	HSS-E	●	C			_basic line	G1/16 - G2	80734	66
	DIN 5156	TG 100 U	HSS-E	T	B			_basic line	G1/16 - G7/8	80714	67
	DIN 5156	TG 100 U	HSS-E	T	C			_basic line	G1/8 - G1	80744	68
	DIN 5156	TG 100 T	HSS-E	X	B			-top line	G1/8 - G1	80804	69
	DIN 5156	TG 100 T	HSS-E	X	C			-top line	G1/16 - G1	80834	70
	DIN 5156	TG 100 T	HSS-E	X	E			-top line	G1/16 - G1	80812	71
	WN	TG 100 T	HSS-E	X	C			-top line	G1/8 - G1/2	80784	72
	DIN 5156	TG 100 GG	HSS-E	●	C				G1/16 - G2	80754	73

P	M	K	N	S	H	Standard	Type	Tool material	Surface	Form	Tolerance	Hole type	d1	Article no.	Page
---	---	---	---	---	---	----------	------	---------------	---------	------	-----------	-----------	----	-------------	------





Fluteless taps for ISO metric threads

	~DIN 371/376	N	HSS-E	T	C	6HX		basic line	M3 - M39	80900	74
	~DIN 371	N	HSS-E-PM	C	C	4HX/6HX		top line	M1 - M20	80920	75
	~DIN 371	N	HSS-E-PM	C	C	6GX		top line	M2 - M20	80925	76





Fluteless taps for ISO metric fine threads

	~DIN 374	N	HSS-E	T	C	6HX		basic line	M6 x 0,75 - M24 x 1,5	80901	77
	~DIN 374	N	HSS-E-PM	C	C	6HX		top line	M8 x 1 - M20 x 1,5	80921	78



Fluteless taps for UNC threads

	~DIN 371/376	N	HSS-E	T	C	2BX		basic line	4 - 40 - 3/4 - 10	80902	79
	~DIN 371	N	HSS-E-PM	C	C	2BX		top line	4 - 40 - 3/4 - 10	80922	80

Fluteless taps for UNF threads

	~DIN 371/374	N	HSS-E	T	C	2BX		basic line	4 - 48 - 3/4 - 16	80903	81
	~DIN 371	N	HSS-E-PM	C	C	2BX		top line	4 - 48 - 3/4 - 16	80923	82

Fluteless taps for BSP threads







	DIN 2189	N	HSS-E	T	C			basic line	G1/16 - G3/4	80904	83
---	-------------	---	-------	---	---	--	---	-------------------	--------------	-------	----

P	M	K	N	S	H	Standard	Type	Tool material	Surface	Form	Tolerance	Hole type	d1	Article no.	Page
---	---	---	---	---	---	----------	------	---------------	---------	------	-----------	-----------	----	-------------	------

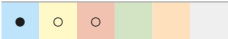

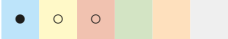

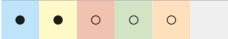

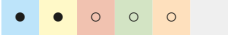
Fluteless taps for BSP threads

	DIN 2189	N	HSS-E-PM	C	C									top line	
													G1/8 - G1/2	80924	84

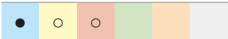
JIS taps for ISO metric threads

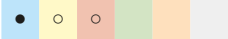
	JISB 4430	TG 100 U	HSS-E	T	B	Class 1/ OH								basic line	
													M2 - M20	80780	85
	JISB 4430	TG 100 U	HSS-E	T	C	Class 1/ OH								basic line	
													M2 - M20	80790	86
	JISB 4430	TG 300 T	HSS-E	X	B	OH2								top line	
													M2 - M20	80880	87
	JISB 4430	TG 100 T	HSS-E	X	C	OH2								top line	
													M2 - M30	80890	88

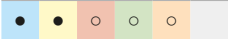
JIS taps for ISO metric fine threads

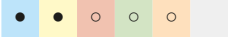
	JISB 4430	TG 100 U	HSS-E	T	B	Class 1/ OH								basic line	
													M6 x 0,75 - M20 x 1,5	80781	89
	JISB 4430	TG 100 U	HSS-E	T	C	Class 1/ OH								basic line	
													M6 x 0,75 - M20 x 1,5	80791	90
	JISB 4430	TG 300 T	HSS-E	X	B	OH2								top line	
													M6 x 0,75 - M20 x 1,5	80881	91
	JISB 4430	TG 100 T	HSS-E	X	C	OH2								top line	
													M4 x 0,5 - M22 x 1,5	80891	92

JIS fluteless taps for ISO metric threads







	JISB 4430	N	HSS-E	T	C	Class 2/ RH									
													M4 - M20	80980	93

P	M	K	N	S	H	Standard	Type	Tool material	Surface	Form	Tolerance	Hole type	d1	Article no.	Page
---	---	---	---	---	---	----------	------	---------------	---------	------	-----------	-----------	----	-------------	------

JIS fluteless taps for ISO metric fine threads

	JISB 4430	N	HSS-E	T	C	Class 2/RH							M6 x 0,75 - M20 x 1,5	80981	94
• • ○ ○															

Taps for manual machining

	WN		HSS-E	○			ISO2/6H								
≤ 1000 ○ • •													M4 - M12	80990	95
	DIN 371	N	HSS-E	○	C	6HX									
• • ○ ○													M4 - M12	80991	96
	DIN 371	VA	HSS-E	○	B	6HX									
• • ○ ○													M4 - M12	80992	97

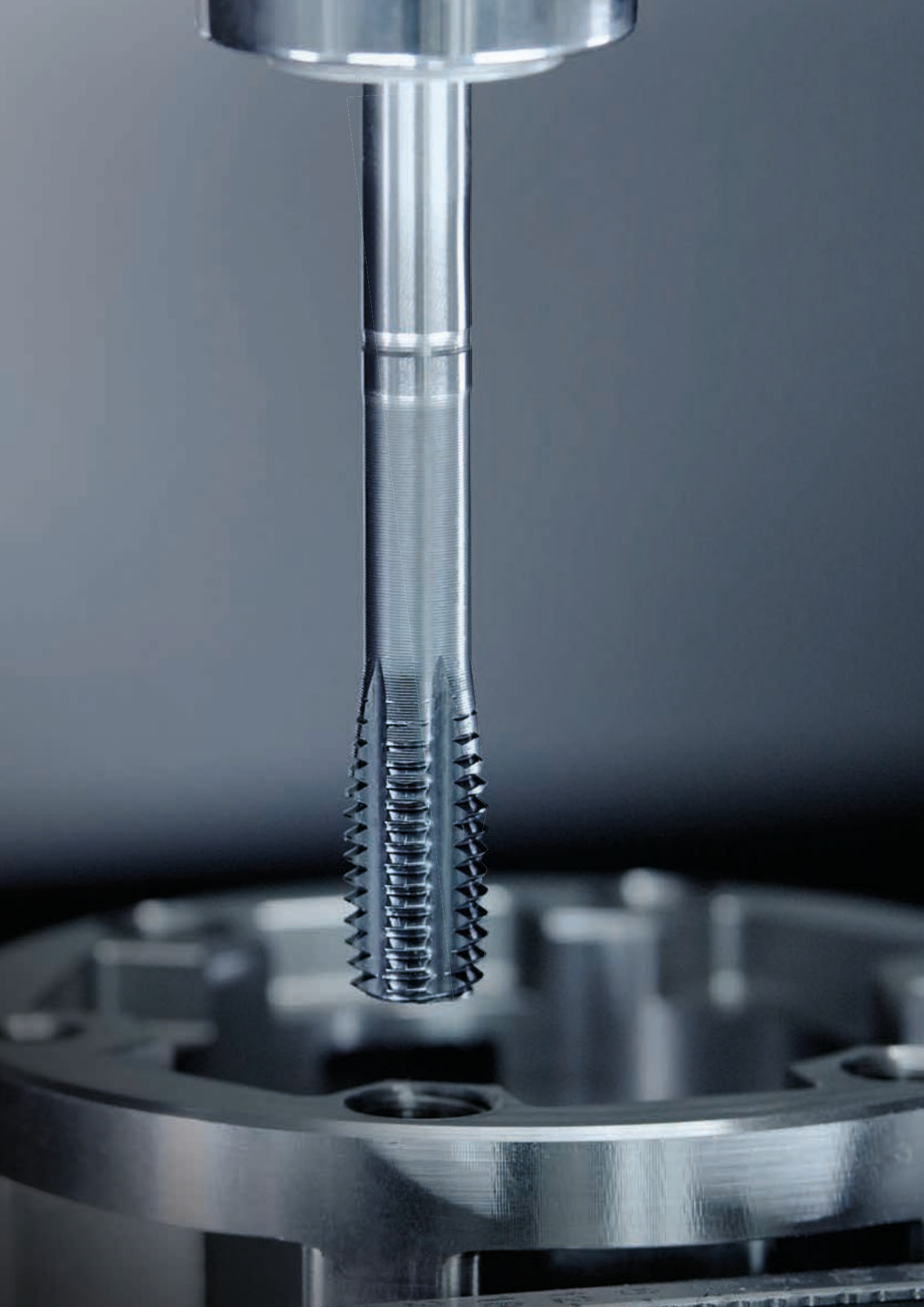

Taps for ISO metric threads

Article no. 80700



P	M	K	N	S	H
•	○	○	○		

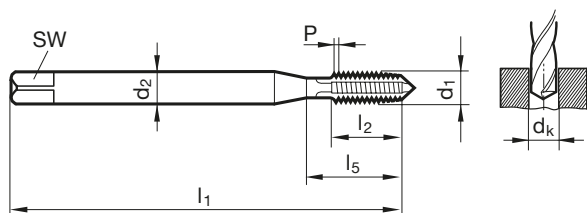

d1	P	d2	SW	dk	l1	l2	l5	Code no.
mm	mm	mm	mm	mm	mm	mm	mm	
M2	0.40	2.80	2.10	1.60	45.00	8.00	13.50	2.000
M3	0.50	3.50	2.70	2.50	56.00	10.00	18.00	3.000
M4	0.70	4.50	3.40	3.30	63.00	12.00	21.00	4.000
M5	0.80	6.00	4.90	4.20	70.00	14.00	25.00	5.000
M6	1.00	6.00	4.90	5.00	80.00	16.00	30.00	6.000
M8	1.25	8.00	6.20	6.80	90.00	17.00	35.00	8.000
M10	1.50	10.00	8.00	8.50	100.00	20.00	39.00	10.000
M12	1.75	9.00	7.00	10.20	110.00	24.00	49.00	12.000
M14	2.00	11.00	9.00	12.00	110.00	26.00	53.00	14.000
M16	2.00	12.00	9.00	14.00	110.00	26.00	54.00	16.000
M18	2.50	14.00	11.00	15.50	125.00	30.00	62.00	18.000
M20	2.50	16.00	12.00	17.50	140.00	32.00	62.00	20.000
M22	2.50	18.00	14.50	19.50	140.00	32.00	62.00	22.000
M24	3.00	18.00	14.50	21.00	160.00	36.00	73.00	24.000
M27	3.00	20.00	16.00	24.00	160.00	36.00	73.00	27.000
M30	3.50	22.00	18.00	26.50	180.00	40.00	85.00	30.000
M36	4.00	28.00	22.00	32.00	200.00	50.00	102.00	36.000

Taps for ISO metric threads

Article no. 80730



P	M	K	N	S	H
●	○	○	○		

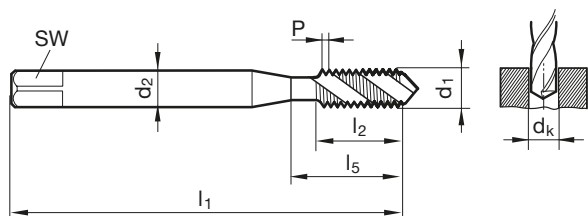

d1	P	d2	SW	dk	l1	l2	l5	Code no.
mm	mm	mm	mm	mm	mm	mm	mm	
M2	0.40	2.80	2.10	1.60	45.00	4.50	13.50	2.000
M3	0.50	3.50	2.70	2.50	56.00	6.00	18.00	3.000
M4	0.70	4.50	3.40	3.30	63.00	7.50	21.00	4.000
M5	0.80	6.00	4.90	4.20	70.00	8.50	25.00	5.000
M6	1.00	6.00	4.90	5.00	80.00	11.00	30.00	6.000
M8	1.25	8.00	6.20	6.80	90.00	14.00	35.00	8.000
M10	1.50	10.00	8.00	8.50	100.00	16.00	39.00	10.000
M12	1.75	9.00	7.00	10.20	110.00	18.50	49.00	12.000
M14	2.00	11.00	9.00	12.00	110.00	20.00	53.00	14.000
M16	2.00	12.00	9.00	14.00	110.00	20.00	54.00	16.000
M20	2.50	16.00	12.00	17.50	140.00	25.00	62.00	20.000
M22	2.50	18.00	14.50	19.50	140.00	27.00	62.00	22.000
M24	3.00	18.00	14.50	21.00	160.00	30.00	73.00	24.000
M27	3.00	20.00	16.00	24.00	160.00	30.00	73.00	27.000
M30	3.50	22.00	18.00	26.50	180.00	35.00	85.00	30.000
M36	4.00	28.00	22.00	32.00	200.00	40.00	102.00	36.000

Taps for ISO metric threads

Article no. 80710



P	M	K	N	S	H
•	○	○			

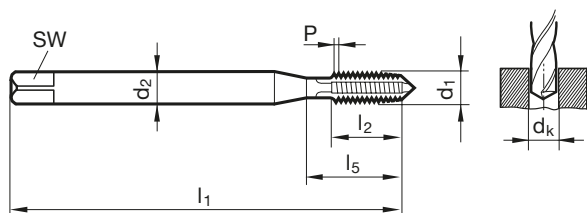

d1	P	d2	SW	dk	l1	l2	l5	Code no.
mm	mm	mm	mm	mm	mm	mm	mm	
M3	0.50	3.50	2.70	2.50	56.00	10.00	18.00	3.000
M4	0.70	4.50	3.40	3.30	63.00	12.00	21.00	4.000
M5	0.80	6.00	4.90	4.20	70.00	14.00	25.00	5.000
M6	1.00	6.00	4.90	5.00	80.00	16.00	30.00	6.000
M8	1.25	8.00	6.20	6.80	90.00	17.00	35.00	8.000
M10	1.50	10.00	8.00	8.50	100.00	20.00	39.00	10.000
M12	1.75	9.00	7.00	10.20	110.00	24.00	49.00	12.000
M14	2.00	11.00	9.00	12.00	110.00	26.00	53.00	14.000
M16	2.00	12.00	9.00	14.00	110.00	26.00	54.00	16.000
M18	2.50	14.00	11.00	15.50	125.00	30.00	62.00	18.000
M20	2.50	16.00	12.00	17.50	140.00	32.00	62.00	20.000
M24	3.00	18.00	14.50	21.00	160.00	36.00	73.00	24.000

Taps for ISO metric threads

Article no. 80740



P	M	K	N	S	H
•	○	○			

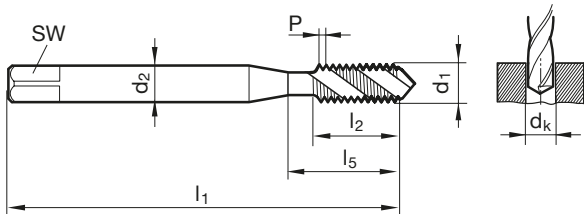

d1	P	d2	SW	dk	l1	l2	l5	Code no.
mm	mm	mm	mm	mm	mm	mm	mm	
M2	0.40	2.80	2.10	1.60	45.00	4.50	13.50	2.000
M3	0.50	3.50	2.70	2.50	56.00	6.00	18.00	3.000
M4	0.70	4.50	3.40	3.30	63.00	7.50	21.00	4.000
M5	0.80	6.00	4.90	4.20	70.00	8.50	25.00	5.000
M6	1.00	6.00	4.90	5.00	80.00	11.00	30.00	6.000
M8	1.25	8.00	6.20	6.80	90.00	14.00	35.00	8.000
M10	1.50	10.00	8.00	8.50	100.00	16.00	39.00	10.000
M12	1.75	9.00	7.00	10.20	110.00	18.50	49.00	12.000
M14	2.00	11.00	9.00	12.00	110.00	20.00	53.00	14.000
M16	2.00	12.00	9.00	14.00	110.00	20.00	54.00	16.000
M20	2.50	16.00	12.00	17.50	140.00	25.00	62.00	20.000
M24	3.00	18.00	14.50	21.00	160.00	30.00	73.00	24.000

Taps for ISO metric threads

Article no. 80745



P	M	K	N	S	H
•	○	○			

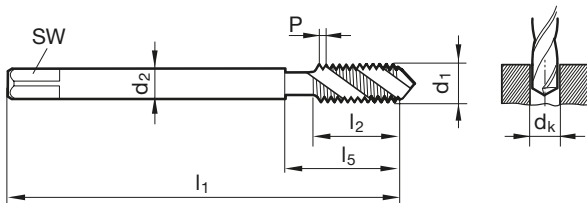

d1	P	d2	SW	dk	l1	l2	l5	Code no.
	mm	mm	mm	mm	mm	mm	mm	
M3	0.50	3.50	2.70	2.50	112.00	6.00	18.00	3.000
M4	0.70	2.80	2.10	3.30	112.00	7.50	77.00	4.000
M5	0.80	3.50	2.70	4.20	125.00	8.50	85.00	5.000
M6	1.00	4.50	3.40	5.00	125.00	11.00	85.00	6.000
M8	1.25	6.00	4.90	6.80	140.00	14.00	95.00	8.000
M10	1.50	7.00	5.50	8.50	160.00	16.00	115.00	10.000
M12	1.75	9.00	7.00	10.20	180.00	18.50	129.00	12.000
M16	2.00	12.00	9.00	14.00	220.00	20.00	163.00	16.000
M20	2.50	16.00	12.00	17.50	280.00	25.00	217.00	20.000

Taps for ISO metric threads

Article no. 80800



P	M	K	N	S	H
•	•	○	○	○	

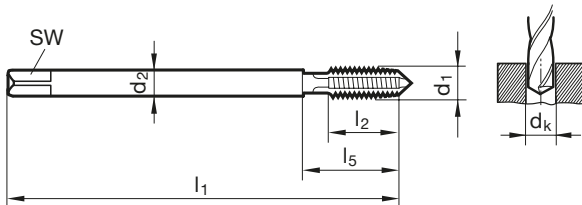

d1	P	d2	SW	dk	l1	l2	l5	Code no.
mm	mm	mm	mm	mm	mm	mm	mm	
M2	0.40	2.80	2.10	1.60	45.00	8.00	13.50	2.000
M2,5	0.45	2.80	2.10	2.05	50.00	9.00	14.50	2.500
M3	0.50	3.50	2.70	2.50	56.00	10.00	18.00	3.000
M3,5	0.60	4.00	3.00	2.90	56.00	12.00	20.00	3.500
M4	0.70	4.50	3.40	3.30	63.00	12.00	21.00	4.000
M5	0.80	6.00	4.90	4.20	70.00	14.00	25.00	5.000
M6	1.00	6.00	4.90	5.00	80.00	16.00	30.00	6.000
M8	1.25	8.00	6.20	6.80	90.00	17.00	35.00	8.000
M10	1.50	10.00	8.00	8.50	100.00	20.00	39.00	10.000
M12	1.75	9.00	7.00	10.20	110.00	24.00	49.00	12.000
M14	2.00	11.00	9.00	12.00	110.00	26.00	53.00	14.000
M16	2.00	12.00	9.00	14.00	110.00	26.00	54.00	16.000
M18	2.50	14.00	11.00	15.50	125.00	30.00	62.00	18.000
M20	2.50	16.00	12.00	17.50	140.00	32.00	62.00	20.000
M24	3.00	18.00	14.50	21.00	160.00	36.00	73.00	24.000
M27	3.00	20.00	16.00	24.00	160.00	36.00	73.00	27.000
M30	3.50	22.00	18.00	26.50	180.00	40.00	85.00	30.000

Taps for ISO metric threads

Article no. 80805



P	M	K	N	S	H
•	•	○	○	○	

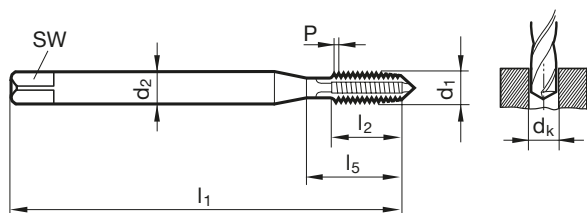

d1	P	d2	SW	dk	l1	l2	l5	Code no.
	mm	mm	mm	mm	mm	mm	mm	
M2	0.40	2.80	2.10	1.60	45.00	8.00	13.50	2.000
M2,5	0.45	2.80	2.10	2.05	50.00	9.00	14.50	2.500
M3	0.50	3.50	2.70	2.50	56.00	10.00	18.00	3.000
M4	0.70	4.50	3.40	3.30	63.00	12.00	21.00	4.000
M5	0.80	6.00	4.90	4.20	70.00	14.00	25.00	5.000
M6	1.00	6.00	4.90	5.00	80.00	16.00	30.00	6.000
M8	1.25	8.00	6.20	6.80	90.00	17.00	35.00	8.000
M10	1.50	10.00	8.00	8.50	100.00	20.00	39.00	10.000
M12	1.75	9.00	7.00	10.20	110.00	24.00	49.00	12.000
M14	2.00	11.00	9.00	12.00	110.00	26.00	53.00	14.000
M16	2.00	12.00	9.00	14.00	110.00	26.00	54.00	16.000
M18	2.50	14.00	11.00	15.50	125.00	30.00	62.00	18.000
M20	2.50	16.00	12.00	17.50	140.00	32.00	62.00	20.000
M24	3.00	18.00	14.50	21.00	160.00	36.00	73.00	24.000
M30	3.50	22.00	18.00	26.50	180.00	40.00	85.00	30.000

Taps for ISO metric threads

Article no. 80808



P	M	K	N	S	H
•	•	○	○	○	

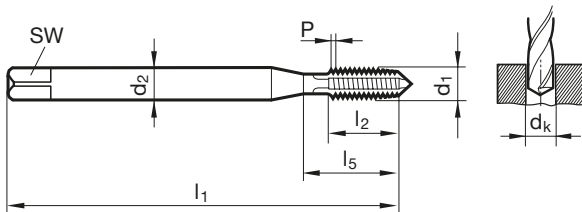

d1	P	d2	SW	dk	l1	l2	l5	Code no.
mm	mm	mm	mm	mm	mm	mm	mm	
M3	0.50	3.50	2.70	2.50	56.00	10.00	18.00	3.000
M4	0.70	4.50	3.40	3.30	63.00	12.00	21.00	4.000
M5	0.80	6.00	4.90	4.20	70.00	14.00	25.00	5.000
M6	1.00	6.00	4.90	5.00	80.00	16.00	30.00	6.000
M8	1.25	8.00	6.20	6.80	90.00	17.00	35.00	8.000
M10	1.50	10.00	8.00	8.50	100.00	20.00	39.00	10.000
M12	1.75	9.00	7.00	10.20	110.00	24.00	49.00	12.000
M14	2.00	11.00	9.00	12.00	110.00	26.00	53.00	14.000
M16	2.00	12.00	9.00	14.00	110.00	26.00	54.00	16.000
M20	2.50	16.00	12.00	17.50	140.00	32.00	62.00	20.000

Taps for ISO metric threads

Article no. 80830



P	M	K	N	S	H
•	•	○	○	○	

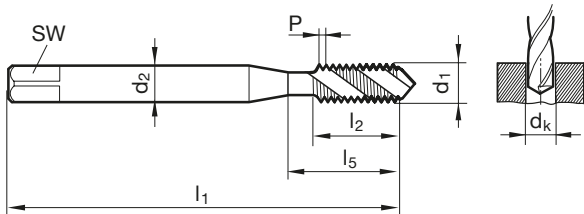

d1	P	d2	SW	dk	l1	l2	l5	Code no.
mm	mm	mm	mm	mm	mm	mm	mm	
M2	0.40	2.80	2.10	1.60	45.00	4.50	13.50	2.000
M2,5	0.45	2.80	2.10	2.05	50.00	5.00	14.50	2.500
M3	0.50	3.50	2.70	2.50	56.00	6.00	18.00	3.000
M4	0.70	4.50	3.40	3.30	63.00	7.50	21.00	4.000
M5	0.80	6.00	4.90	4.20	70.00	8.50	25.00	5.000
M6	1.00	6.00	4.90	5.00	80.00	11.00	30.00	6.000
M8	1.25	8.00	6.20	6.80	90.00	14.00	35.00	8.000
M10	1.50	10.00	8.00	8.50	100.00	16.00	39.00	10.000
M12	1.75	9.00	7.00	10.20	110.00	18.50	49.00	12.000
M14	2.00	11.00	9.00	12.00	110.00	20.00	53.00	14.000
M16	2.00	12.00	9.00	14.00	110.00	20.00	54.00	16.000
M18	2.50	14.00	11.00	15.50	125.00	25.00	62.00	18.000
M20	2.50	16.00	12.00	17.50	140.00	25.00	62.00	20.000
M24	3.00	18.00	14.50	21.00	160.00	30.00	73.00	24.000
M30	3.50	22.00	18.00	26.50	180.00	35.00	85.00	30.000

Taps for ISO metric threads

Article no. 80835



P	M	K	N	S	H
•	•	○	○	○	

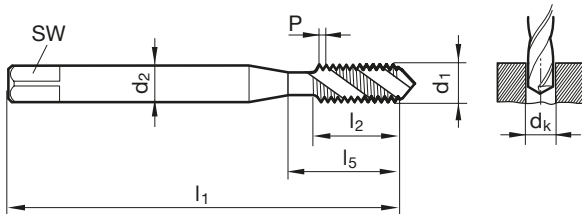

d1	P	d2	SW	dk	l1	l2	l5	Code no.
mm	mm	mm	mm	mm	mm	mm	mm	
M2	0.40	2.80	2.10	1.60	45.00	4.50	13.50	2.000
M2,5	0.45	2.80	2.10	2.05	50.00	5.00	14.50	2.500
M3	0.50	3.50	2.70	2.50	56.00	6.00	18.00	3.000
M3,5	0.60	4.00	3.00	2.90	56.00	7.00	20.00	3.500
M4	0.70	4.50	3.40	3.30	63.00	7.50	21.00	4.000
M5	0.80	6.00	4.90	4.20	70.00	8.50	25.00	5.000
M6	1.00	6.00	4.90	5.00	80.00	11.00	30.00	6.000
M8	1.25	8.00	6.20	6.80	90.00	14.00	35.00	8.000
M10	1.50	10.00	8.00	8.50	100.00	16.00	39.00	10.000
M12	1.75	9.00	7.00	10.20	110.00	18.50	49.00	12.000
M14	2.00	11.00	9.00	12.00	110.00	20.00	53.00	14.000
M16	2.00	12.00	9.00	14.00	110.00	20.00	54.00	16.000
M18	2.50	14.00	11.00	15.50	125.00	25.00	62.00	18.000
M20	2.50	16.00	12.00	17.50	140.00	25.00	62.00	20.000
M24	3.00	18.00	14.50	21.00	160.00	30.00	73.00	24.000
M30	3.50	22.00	18.00	26.50	180.00	35.00	85.00	30.000

Taps for ISO metric threads

Article no. 80806



P	M	K	N	S	H
•	•	○	○	○	

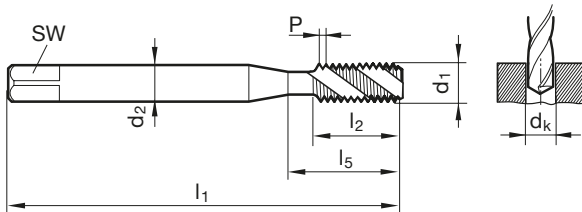

d1	P	d2	SW	dk	l1	l2	l5	Code no.
mm	mm	mm	mm	mm	mm	mm	mm	
M3	0.50	3.50	2.70	2.50	56.00	6.00	18.00	3.000
M4	0.70	4.50	3.40	3.30	63.00	7.50	21.00	4.000
M5	0.80	6.00	4.90	4.20	70.00	8.50	25.00	5.000
M6	1.00	6.00	4.90	5.00	80.00	11.00	30.00	6.000
M8	1.25	8.00	6.20	6.80	90.00	14.00	35.00	8.000
M10	1.50	10.00	8.00	8.50	100.00	16.00	39.00	10.000
M12	1.75	9.00	7.00	10.20	110.00	18.50	49.00	12.000
M14	2.00	11.00	9.00	12.00	110.00	20.00	53.00	14.000
M16	2.00	12.00	9.00	14.00	110.00	20.00	54.00	16.000
M20	2.50	16.00	12.00	17.50	140.00	25.00	62.00	20.000

Taps for ISO metric threads

Article no. 80810



P	M	K	N	S	H
•	•	•	○	○	

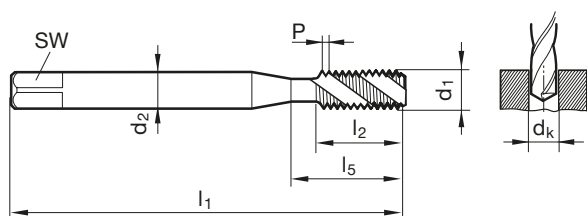

d1	P	d2	SW	dk	l1	l2	l5	Code no.
mm	mm	mm	mm	mm	mm	mm	mm	
M2	0.40	2.80	2.10	1.60	45.00	4.50	13.50	2.000
M2,5	0.45	2.80	2.10	2.05	50.00	5.00	14.50	2.500
M3	0.50	3.50	2.70	2.50	56.00	6.00	18.00	3.000
M3,5	0.60	4.00	3.00	2.90	56.00	7.00	20.00	3.500
M4	0.70	4.50	3.40	3.30	63.00	7.50	21.00	4.000
M5	0.80	6.00	4.90	4.20	70.00	8.50	25.00	5.000
M6	1.00	6.00	4.90	5.00	80.00	11.00	30.00	6.000
M8	1.25	8.00	6.20	6.80	90.00	14.00	35.00	8.000
M10	1.50	10.00	8.00	8.50	100.00	16.00	39.00	10.000
M12	1.75	9.00	7.00	10.20	110.00	18.50	49.00	12.000
M14	2.00	11.00	9.00	12.00	110.00	20.00	53.00	14.000
M16	2.00	12.00	9.00	14.00	110.00	20.00	54.00	16.000
M18	2.50	14.00	11.00	15.50	125.00	25.00	62.00	18.000
M20	2.50	16.00	12.00	17.50	140.00	25.00	62.00	20.000
M24	3.00	18.00	14.50	21.00	160.00	30.00	73.00	24.000
M30	3.50	22.00	18.00	26.50	180.00	35.00	85.00	30.000

Taps for ISO metric threads

Article no. 80782



P	M	K	N	S	H
•	•	○	○	○	



long version

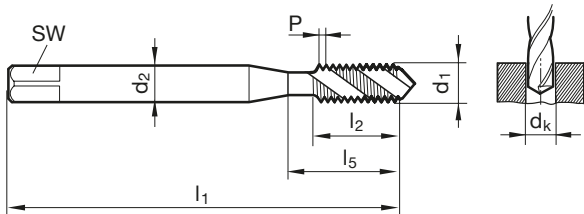

d1	P	d2	SW	dk	l1	l2	l5	Code no.
mm	mm	mm	mm	mm	mm	mm	mm	
M3	0.50	3.50	2.70	2.50	90.00	6.00	18.00	3.000
M4	0.70	4.50	3.40	3.30	125.00	7.50	21.00	4.000
M5	0.80	6.00	4.90	4.20	140.00	8.50	25.00	5.000
M6	1.00	6.00	4.90	5.00	160.00	11.00	30.00	6.000
M8	1.25	8.00	6.20	6.80	180.00	14.00	35.00	8.010
M10	1.50	10.00	8.00	8.50	200.00	16.00	39.00	10.010
M12	1.75	9.00	7.00	10.20	220.00	18.50	158.00	12.000
M14	2.00	11.00	9.00	12.00	220.00	20.00	160.00	14.000
M16	2.00	12.00	9.00	14.00	220.00	20.00	160.00	16.000
M20	2.50	16.00	12.00	17.50	280.00	25.00	217.00	20.000



Taps for ISO metric threads

Article no. 80760



P	M	K	N	S	H
			•		

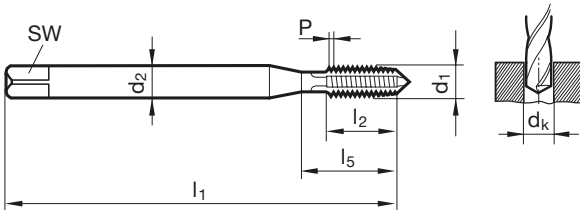

d1	P	d2	SW	dk	l1	l2	l5	Code no.
	mm	mm	mm	mm	mm	mm	mm	
M2	0.40	2.80	2.10	1.60	45.00	8.00	13.50	2.000
M2,2	0.45	2.80	2.10	1.75	45.00	9.00	14.50	2.200
M2,5	0.45	2.80	2.10	2.05	50.00	9.00	14.50	2.500
M3	0.50	3.50	2.70	2.50	56.00	10.00	18.00	3.000
M4	0.70	4.50	3.40	3.30	63.00	12.00	21.00	4.000
M5	0.80	6.00	4.90	4.20	70.00	14.00	25.00	5.000
M6	1.00	6.00	4.90	5.00	80.00	16.00	30.00	6.000
M8	1.25	8.00	6.20	6.80	90.00	17.00	35.00	8.000
M10	1.50	10.00	8.00	8.50	100.00	20.00	39.00	10.000
M12	1.75	9.00	7.00	10.20	110.00	24.00	49.00	12.000
M14	2.00	11.00	9.00	12.00	110.00	26.00	53.00	14.000
M16	2.00	12.00	9.00	14.00	110.00	26.00	54.00	16.000
M18	2.50	14.00	11.00	15.50	125.00	30.00	62.00	18.000
M20	2.50	16.00	12.00	17.50	140.00	32.00	62.00	20.000
M22	2.50	18.00	14.50	19.50	140.00	32.00	62.00	22.000



HARTNER

Taps for ISO metric threads

Article no. 80761



P	M	K	N	S	H
			•		

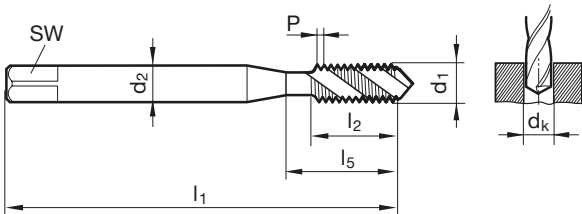

d1	P	d2	SW	dk	l1	l2	l5	Code no.
mm	mm	mm	mm	mm	mm	mm	mm	
M1,6	0.35	2.50	2.10	1.25	40.00	6.40	6.40	1.600
M2	0.40	2.80	2.10	1.60	45.00	4.50	13.50	2.000
M2,2	0.45	2.80	2.10	1.75	45.00	5.00	14.50	2.200
M2,3	0.40	2.80	2.10	1.90	45.00	4.50	14.50	2.300
M2,5	0.45	2.80	2.10	2.05	50.00	5.00	14.50	2.500
M2,6	0.45	2.80	2.10	2.15	50.00	5.00	14.50	2.600
M3	0.50	3.50	2.70	2.50	56.00	6.00	18.00	3.000
M3,5	0.60	4.00	3.00	2.90	56.00	7.00	20.00	3.500
M4	0.70	4.50	3.40	3.30	63.00	7.50	21.00	4.000
M5	0.80	6.00	4.90	4.20	70.00	8.50	25.00	5.000
M6	1.00	6.00	4.90	5.00	80.00	11.00	30.00	6.000
M8	1.25	8.00	6.20	6.80	90.00	14.00	35.00	8.000
M10	1.50	10.00	8.00	8.50	100.00	16.00	39.00	10.000
M12	1.75	9.00	7.00	10.20	110.00	18.50	49.00	12.000
M14	2.00	11.00	9.00	12.00	110.00	20.00	53.00	14.000
M16	2.00	12.00	9.00	14.00	110.00	20.00	54.00	16.000
M20	2.50	16.00	12.00	17.50	140.00	25.00	62.00	20.000
M24	3.00	18.00	14.50	21.00	160.00	30.00	73.00	24.000



HARTNER

Taps for ISO metric threads

Article no. 80750



P	M	K	N	S	H
		•			

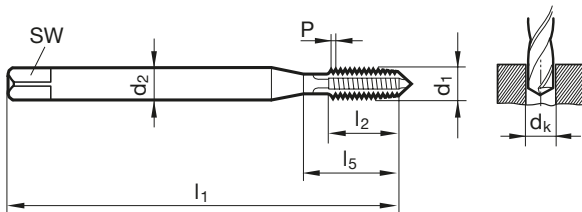

d1	P	d2	SW	dk	l1	l2	l5	Code no.
mm	mm	mm	mm	mm	mm	mm	mm	
M3	0.50	3.50	2.70	2.50	56.00	10.00	18.00	3.000
M3,5	0.60	4.00	3.00	2.90	56.00	12.00	20.00	3.500
M4	0.70	4.50	3.40	3.30	63.00	12.00	21.00	4.000
M5	0.80	6.00	4.90	4.20	70.00	14.00	25.00	5.000
M6	1.00	6.00	4.90	5.00	80.00	16.00	30.00	6.000
M8	1.25	8.00	6.20	6.80	90.00	17.00	35.00	8.000
M10	1.50	10.00	8.00	8.50	100.00	20.00	39.00	10.000
M12	1.75	9.00	7.00	10.20	110.00	24.00	49.00	12.000
M14	2.00	11.00	9.00	12.00	110.00	26.00	53.00	14.000
M16	2.00	12.00	9.00	14.00	110.00	26.00	54.00	16.000
M18	2.50	14.00	11.00	15.50	125.00	30.00	62.00	18.000
M20	2.50	16.00	12.00	17.50	140.00	32.00	62.00	20.000
M22	2.50	18.00	14.50	19.50	140.00	32.00	62.00	22.000
M24	3.00	18.00	14.50	21.00	160.00	36.00	73.00	24.000
M27	3.00	20.00	16.00	24.00	160.00	36.00	73.00	27.000
M30	3.50	22.00	18.00	26.50	180.00	40.00	85.00	30.000



Taps with coolant ducts for ISO metric threads

Article no. 80850



P	M	K	N	S	H
•		•	•		



<M16 made of HSS-E-PM, ≥M16 made of HSS-E

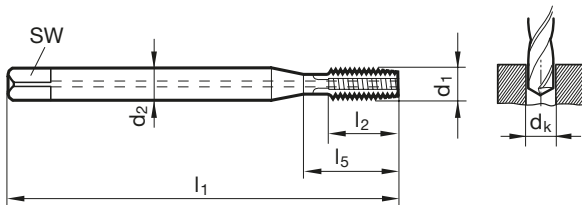

d1	P	d2	SW	dk	l1	l2	l5	Code no.
mm	mm	mm	mm	mm	mm	mm	mm	
M5	0.80	6.00	4.90	4.20	70.00	14.00	25.00	5.000
M6	1.00	6.00	4.90	5.00	80.00	16.00	30.00	6.000
M8	1.25	8.00	6.20	6.80	90.00	17.00	35.00	8.000
M10	1.50	10.00	8.00	8.50	100.00	20.00	39.00	10.000
M12	1.75	9.00	7.00	10.20	110.00	24.00	49.00	12.000
M14	2.00	11.00	9.00	12.00	110.00	26.00	53.00	14.000
M16	2.00	12.00	9.00	14.00	110.00	26.00	54.00	16.000
M20	2.50	16.00	12.00	17.50	140.00	32.00	62.00	20.000
M24	3.00	18.00	14.50	21.00	160.00	36.00	73.00	24.000
M27	3.00	20.00	16.00	24.00	160.00	36.00	73.00	27.000
M30	3.50	22.00	18.00	26.50	180.00	40.00	85.00	30.000
M33	3.50	25.00	20.00	29.50	180.00	40.00	91.00	33.000
M36	4.00	28.00	22.00	32.00	200.00	50.00	102.00	36.000
M39	4.00	32.00	24.00	35.00	200.00	50.00	107.00	39.000

Taps for ISO metric fine threads

Article no. 80701

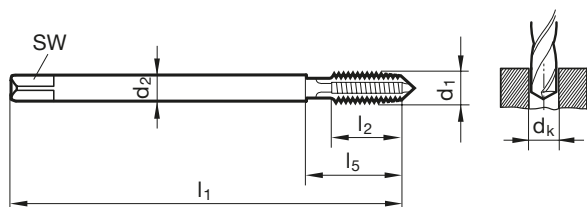
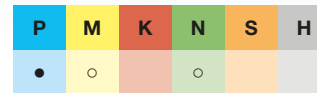

d1	d2 mm	SW mm	dk mm	l1 mm	l2 mm	l5 mm	Code no.
M4 x 0,5	2.80	2.10	3.50	63.00	8.00	21.00	4.003
M5 x 0,5	3.50	2.70	4.50	70.00	10.00	25.00	5.003
M6 x 0,75	4.50	3.40	5.20	80.00	13.00	30.00	6.004
M8 x 0,75	6.00	4.90	7.20	80.00	14.00	30.00	8.004
M8 x 1	6.00	4.90	7.00	90.00	17.00	35.00	8.005
M10 x 1	7.00	5.50	9.00	90.00	16.00	35.00	10.005
M10 x 1,25	7.00	5.50	8.80	100.00	20.00	39.00	10.006
M12 x 1	9.00	7.00	11.00	100.00	20.00	40.00	12.005
M12 x 1,5	9.00	7.00	10.50	100.00	20.00	40.00	12.007
M14 x 1,5	11.00	9.00	12.50	100.00	20.00	40.00	14.007
M16 x 1,5	12.00	9.00	14.50	100.00	22.00	44.00	16.007
M18 x 1,5	14.00	11.00	16.50	110.00	25.00	44.00	18.007
M20 x 1,5	16.00	12.00	18.50	125.00	25.00	44.00	20.007
M22 x 1,5	18.00	14.50	20.50	125.00	25.00	44.00	22.007
M24 x 1,5	18.00	14.50	22.50	140.00	28.00	48.00	24.007
M24 x 2	18.00	14.50	22.00	140.00	28.00	48.00	24.008
M26 x 1,5	18.00	14.50	24.50	140.00	28.00	50.00	26.007
M27 x 1,5	20.00	16.00	25.50	140.00	28.00	53.00	27.007
M27 x 2	20.00	16.00	25.00	140.00	28.00	53.00	27.008
M28 x 1,5	20.00	16.00	26.50	140.00	28.00	53.00	28.007
M30 x 1,5	22.00	18.00	28.50	150.00	28.00	53.00	30.007
M30 x 2	22.00	18.00	28.00	150.00	28.00	53.00	30.008
M32 x 1,5	22.00	18.00	30.50	150.00	28.00	53.00	32.007
M36 x 1,5	28.00	22.00	34.50	170.00	30.00	56.00	36.007
M42 x 1,5	32.00	24.00	40.50	170.00	30.00	57.00	42.007

Taps for ISO metric fine threads

Article no. 80731

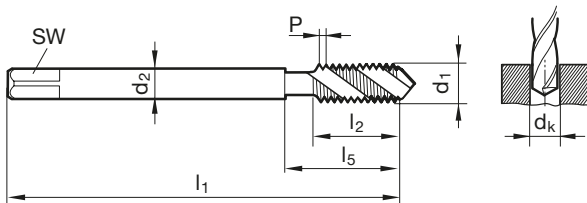

d1	d2 mm	SW mm	dk mm	l1 mm	l2 mm	l5 mm	Code no.
M4 x 0,5	2.80	2.10	3.50	63.00	5.00	21.00	4.003
M5 x 0,5	3.50	2.70	4.50	70.00	5.00	25.00	5.003
M6 x 0,75	4.50	3.40	5.20	80.00	8.00	30.00	6.004
M8 x 1	6.00	4.90	7.00	90.00	11.00	35.00	8.005
M10 x 1	7.00	5.50	9.00	90.00	11.00	35.00	10.005
M10 x 1,25	7.00	5.50	8.80	100.00	14.00	39.00	10.006
M12 x 1	9.00	7.00	11.00	100.00	11.00	40.00	12.005
M12 x 1,25	9.00	7.00	10.80	100.00	15.00	40.00	12.006
M12 x 1,5	9.00	7.00	10.50	100.00	15.00	40.00	12.007
M14 x 1	11.00	9.00	13.00	100.00	11.00	40.00	14.005
M14 x 1,25	11.00	9.00	12.80	100.00	15.00	40.00	14.006
M14 x 1,5	11.00	9.00	12.50	100.00	15.00	40.00	14.007
M16 x 1	12.00	9.00	15.00	100.00	11.00	44.00	16.005
M16 x 1,5	12.00	9.00	14.50	100.00	15.00	44.00	16.007
M18 x 1	14.00	11.00	17.00	110.00	12.00	44.00	18.005
M18 x 1,5	14.00	11.00	16.50	110.00	16.00	44.00	18.007
M20 x 1,5	16.00	12.00	18.50	125.00	16.00	44.00	20.007
M22 x 1,5	18.00	14.50	20.50	125.00	16.00	44.00	22.007
M24 x 2	18.00	14.50	22.00	140.00	22.00	48.00	24.008
M26 x 1,5	18.00	14.50	24.50	140.00	20.00	50.00	26.007
M27 x 1,5	20.00	16.00	25.50	140.00	20.00	53.00	27.007
M27 x 2	20.00	16.00	25.00	140.00	20.00	53.00	27.008
M28 x 1,5	20.00	16.00	26.50	140.00	20.00	53.00	28.007
M30 x 1,5	22.00	18.00	28.50	150.00	20.00	53.00	30.007
M30 x 2	22.00	18.00	28.00	150.00	20.00	53.00	30.008

Taps for ISO metric fine threads

Article no. 80711



P	M	K	N	S	H
•	○				

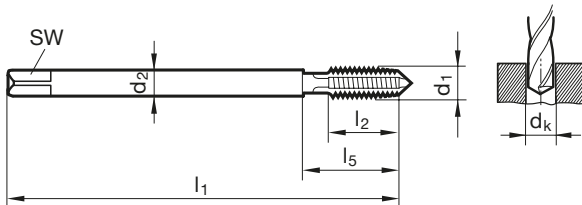

d1	d2 mm	SW mm	dk mm	l1 mm	l2 mm	l5 mm	Code no.
M5 x 0,5	3.50	2.70	4.50	70.00	10.00	25.00	5.003
M6 x 0,75	4.50	3.40	5.20	80.00	13.00	30.00	6.004
M8 x 1	6.00	4.90	7.00	90.00	17.00	35.00	8.005
M10 x 1	7.00	5.50	9.00	90.00	16.00	35.00	10.005
M12 x 1	9.00	7.00	11.00	100.00	20.00	40.00	12.005
M12 x 1,5	9.00	7.00	10.50	100.00	20.00	40.00	12.007
M14 x 1,5	11.00	9.00	12.50	100.00	20.00	40.00	14.007
M16 x 1,5	12.00	9.00	14.50	100.00	22.00	44.00	16.007
M18 x 1,5	14.00	11.00	16.50	110.00	25.00	44.00	18.007
M20 x 1,5	16.00	12.00	18.50	125.00	25.00	44.00	20.007
M22 x 1,5	18.00	14.50	20.50	125.00	25.00	44.00	22.007
M24 x 1,5	18.00	14.50	22.50	140.00	28.00	48.00	24.007

Taps for ISO metric fine threads

Article no. 80741



P	M	K	N	S	H
•	○				

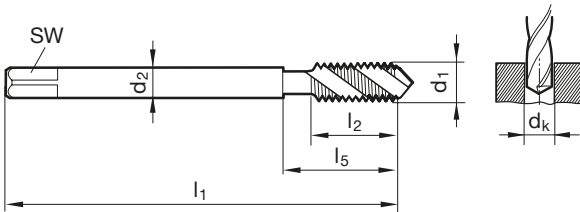

d1	d2 mm	SW mm	dk mm	l1 mm	l2 mm	l5 mm	Code no.
M5 x 0,5	3.50	2.70	4.50	70.00	5.00	25.00	5.003
M6 x 0,75	4.50	3.40	5.20	80.00	8.00	30.00	6.004
M8 x 0,75	6.00	4.90	7.20	80.00	8.00	30.00	8.004
M8 x 1	6.00	4.90	7.00	90.00	11.00	35.00	8.005
M10 x 1	7.00	5.50	9.00	90.00	11.00	35.00	10.005
M10 x 1,25	7.00	5.50	8.80	100.00	14.00	39.00	10.006
M12 x 1	9.00	7.00	11.00	100.00	11.00	40.00	12.005
M12 x 1,25	9.00	7.00	10.80	100.00	15.00	40.00	12.006
M12 x 1,5	9.00	7.00	10.50	100.00	15.00	40.00	12.007
M14 x 1	11.00	9.00	13.00	100.00	11.00	40.00	14.005
M14 x 1,5	11.00	9.00	12.50	100.00	15.00	40.00	14.007
M16 x 1	12.00	9.00	15.00	100.00	11.00	44.00	16.005
M16 x 1,5	12.00	9.00	14.50	100.00	15.00	44.00	16.007
M18 x 1	14.00	11.00	17.00	110.00	12.00	44.00	18.005
M18 x 1,5	14.00	11.00	16.50	110.00	16.00	44.00	18.007
M20 x 1,5	16.00	12.00	18.50	125.00	16.00	44.00	20.007
M22 x 1,5	18.00	14.50	20.50	125.00	16.00	44.00	22.007
M24 x 1,5	18.00	14.50	22.50	140.00	16.00	48.00	24.007
M24 x 2	18.00	14.50	22.00	140.00	22.00	48.00	24.008

Taps for ISO metric fine threads

Article no. 80801



P	M	K	N	S	H
•	•	•	•	○	

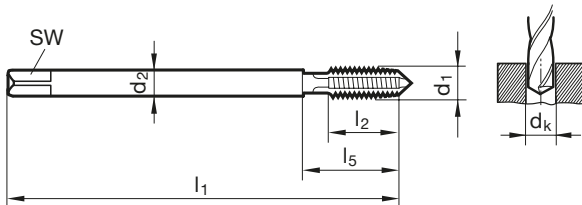

d1	d2 mm	SW mm	dk mm	l1 mm	l2 mm	l5 mm	Code no.
M3 x 0,35	2.20	1.80	2.65	56.00	7.00	18.00	3.002
M4 x 0,5	2.80	2.10	3.50	63.00	8.00	21.00	4.003
M5 x 0,5	3.50	2.70	4.50	70.00	10.00	25.00	5.003
M6 x 0,5	4.50	3.40	5.50	80.00	13.00	30.00	6.003
M6 x 0,75	4.50	3.40	5.20	80.00	13.00	30.00	6.004
M8 x 0,75	6.00	4.90	7.20	80.00	14.00	30.00	8.004
M8 x 1	6.00	4.90	7.00	90.00	17.00	35.00	8.005
M10 x 1	7.00	5.50	9.00	90.00	16.00	35.00	10.005
M10 x 1,25	7.00	5.50	8.80	100.00	20.00	39.00	10.006
M12 x 1	9.00	7.00	11.00	100.00	20.00	40.00	12.005
M12 x 1,25	9.00	7.00	10.80	100.00	20.00	40.00	12.006
M12 x 1,5	9.00	7.00	10.50	100.00	20.00	40.00	12.007
M14 x 1,5	11.00	9.00	12.50	100.00	20.00	40.00	14.007
M16 x 1,5	12.00	9.00	14.50	100.00	22.00	44.00	16.007
M18 x 1,5	14.00	11.00	16.50	110.00	25.00	44.00	18.007
M20 x 1,5	16.00	12.00	18.50	125.00	25.00	44.00	20.007
M24 x 1,5	18.00	14.50	22.50	140.00	28.00	48.00	24.007
M24 x 2	18.00	14.50	22.00	140.00	28.00	48.00	24.008
M36 x 2	28.00	22.00	34.00	170.00	30.00	56.00	36.008

Taps for ISO metric fine threads

Article no. 80809



P	M	K	N	S	H
•	•	•	•	○	

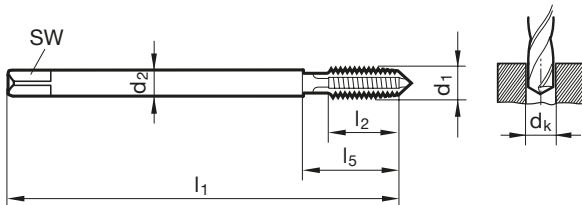

d1	d2 mm	SW mm	dk mm	l1 mm	l2 mm	l5 mm	Code no.
M8 x 1	6.00	4.90	7.00	90.00	17.00	35.00	8.005
M10 x 1	7.00	5.50	9.00	90.00	16.00	35.00	10.005
M10 x 1,25	7.00	5.50	8.80	100.00	20.00	39.00	10.006
M12 x 1	9.00	7.00	11.00	100.00	20.00	40.00	12.005
M12 x 1,25	9.00	7.00	10.80	100.00	20.00	40.00	12.006
M12 x 1,5	9.00	7.00	10.50	100.00	20.00	40.00	12.007
M14 x 1,5	11.00	9.00	12.50	100.00	20.00	40.00	14.007
M16 x 1,5	12.00	9.00	14.50	100.00	22.00	44.00	16.007
M18 x 1,5	14.00	11.00	16.50	110.00	25.00	44.00	18.007
M20 x 1,5	16.00	12.00	18.50	125.00	25.00	44.00	20.007
M24 x 1,5	18.00	14.50	22.50	140.00	28.00	48.00	24.007

Taps for ISO metric fine threads

Article no. 80831



P	M	K	N	S	H
•	•	•	•	○	

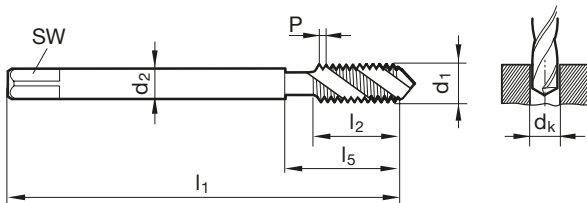

d1	d2 mm	SW mm	dk mm	l1 mm	l2 mm	l5 mm	Code no.
M6 x 0,75	4.50	3.40	5.20	80.00	8.00	30.00	6.004
M8 x 0,75	6.00	4.90	7.20	80.00	8.00	30.00	8.004
M8 x 1	6.00	4.90	7.00	90.00	11.00	35.00	8.005
M10 x 1	7.00	5.50	9.00	90.00	11.00	35.00	10.005
M10 x 1,25	7.00	5.50	8.80	100.00	14.00	39.00	10.006
M12 x 1	9.00	7.00	11.00	100.00	11.00	40.00	12.005
M12 x 1,25	9.00	7.00	10.80	100.00	15.00	40.00	12.006
M12 x 1,5	9.00	7.00	10.50	100.00	15.00	40.00	12.007
M14 x 1,5	11.00	9.00	12.50	100.00	15.00	40.00	14.007
M16 x 1,5	12.00	9.00	14.50	100.00	15.00	44.00	16.007
M18 x 1,5	14.00	11.00	16.50	110.00	16.00	44.00	18.007
M20 x 1,5	16.00	12.00	18.50	125.00	16.00	44.00	20.007
M24 x 1,5	18.00	14.50	22.50	140.00	16.00	48.00	24.007

Taps for ISO metric fine threads

Article no. 80807



P	M	K	N	S	H
•	•	•	•	○	

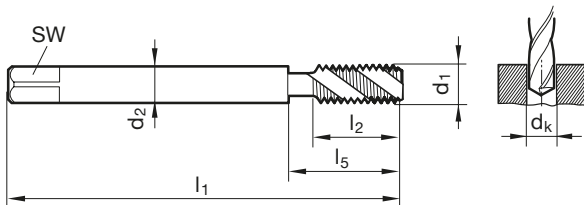

d1	d2 mm	SW mm	dk mm	l1 mm	l2 mm	l5 mm	Code no.
M8 x 1	6.00	4.90	7.00	90.00	11.00	35.00	8.005
M10 x 1	7.00	5.50	9.00	90.00	11.00	35.00	10.005
M10 x 1,25	7.00	5.50	8.80	100.00	14.00	39.00	10.006
M12 x 1	9.00	7.00	11.00	100.00	11.00	40.00	12.005
M12 x 1,25	9.00	7.00	10.80	100.00	15.00	40.00	12.006
M12 x 1,5	9.00	7.00	10.50	100.00	15.00	40.00	12.007
M14 x 1,5	11.00	9.00	12.50	100.00	15.00	40.00	14.007
M16 x 1,5	12.00	9.00	14.50	100.00	15.00	44.00	16.007
M18 x 1,5	14.00	11.00	16.50	110.00	16.00	44.00	18.007
M20 x 1,5	16.00	12.00	18.50	125.00	16.00	44.00	20.007
M24 x 1,5	18.00	14.50	22.50	140.00	16.00	48.00	24.007

Taps for ISO metric fine threads

Article no. 80811



P	M	K	N	S	H
•	•	•	•	○	

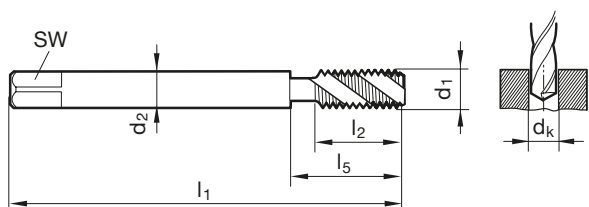

d1	d2 mm	SW mm	dk mm	l1 mm	l2 mm	l5 mm	Code no.
M6 x 0,75	4.50	3.40	5.20	80.00	8.00	30.00	6.004
M8 x 0,75	6.00	4.90	7.20	80.00	8.00	30.00	8.004
M8 x 1	6.00	4.90	7.00	90.00	11.00	35.00	8.005
M10 x 1	7.00	5.50	9.00	90.00	11.00	35.00	10.005
M10 x 1,25	7.00	5.50	8.80	100.00	14.00	39.00	10.006
M12 x 1	9.00	7.00	11.00	100.00	11.00	40.00	12.005
M12 x 1,25	9.00	7.00	10.80	100.00	15.00	40.00	12.006
M12 x 1,5	9.00	7.00	10.50	100.00	15.00	40.00	12.007
M14 x 1,5	11.00	9.00	12.50	100.00	15.00	40.00	14.007
M16 x 1,5	12.00	9.00	14.50	100.00	15.00	44.00	16.007
M18 x 1,5	14.00	11.00	16.50	110.00	16.00	44.00	18.007
M20 x 1,5	16.00	12.00	18.50	125.00	16.00	44.00	20.007
M24 x 1,5	18.00	14.50	22.50	140.00	16.00	48.00	24.007

Taps for ISO metric fine threads

Article no. 80783



P	M	K	N	S	H
•	•	○	○	○	



long version

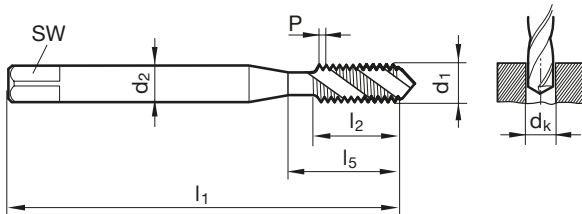

d1	d2 mm	SW mm	dk mm	l1 mm	l2 mm	l5 mm	Code no.
M8 x 0,75	6.00	4.90	7.20	180.00	14.00	120.00	8.004
M8 x 1	6.00	4.90	7.00	180.00	14.00	120.00	8.005
M9 x 1	7.00	5.50	8.00	200.00	14.00	140.00	9.005
M10 x 1	7.00	5.50	9.00	200.00	16.00	140.00	10.005
M12 x 1,5	9.00	7.00	10.50	220.00	18.50	158.00	12.007
M14 x 1,5	11.00	9.00	12.50	220.00	20.00	160.00	14.007
M16 x 1,5	12.00	9.00	14.50	220.00	20.00	160.00	16.007
M20 x 1,5	16.00	12.00	18.50	280.00	25.00	217.00	20.007



Taps for ISO metric fine threads

Article no. 80751

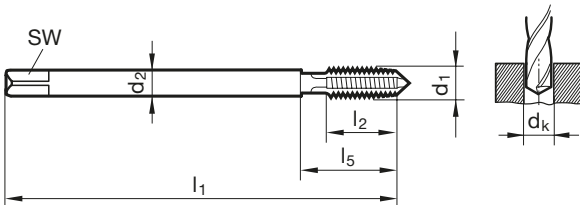

d1	d2 mm	SW mm	dk mm	l1 mm	l2 mm	l5 mm	Code no.
M4 x 0,5	2.80	2.10	3.50	63.00	8.00	21.00	4.003
M5 x 0,5	3.50	2.70	4.50	70.00	10.00	25.00	5.003
M6 x 0,75	4.50	3.40	5.20	80.00	13.00	30.00	6.004
M8 x 0,75	6.00	4.90	7.20	80.00	14.00	30.00	8.004
M8 x 1	6.00	4.90	7.00	90.00	17.00	35.00	8.005
M10 x 1	7.00	5.50	9.00	90.00	16.00	35.00	10.005
M12 x 1	9.00	7.00	11.00	100.00	20.00	40.00	12.005
M12 x 1,5	9.00	7.00	10.50	100.00	20.00	40.00	12.007
M14 x 1,5	11.00	9.00	12.50	100.00	20.00	40.00	14.007
M16 x 1,5	12.00	9.00	14.50	100.00	22.00	44.00	16.007
M18 x 1,5	14.00	11.00	16.50	110.00	25.00	44.00	18.007
M20 x 1,5	16.00	12.00	18.50	125.00	25.00	44.00	20.007
M22 x 1,5	18.00	14.50	20.50	125.00	25.00	44.00	22.007
M24 x 1,5	18.00	14.50	22.50	140.00	28.00	48.00	24.007
M27 x 1,5	20.00	16.00	25.50	140.00	28.00	53.00	27.007
M30 x 1,5	22.00	18.00	28.50	150.00	28.00	53.00	30.007



Taps with coolant ducts for ISO metric fine threads

Article no. 80851



P	M	K	N	S	H
•		•	○		

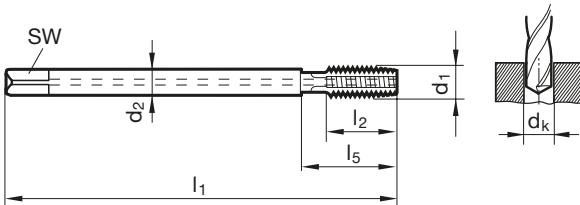

d1	d2 mm	SW mm	dk mm	l1 mm	l2 mm	l5 mm	Code no.
M6 x 0,75	4.50	3.40	5.20	80.00	13.00	30.00	6.004
M8 x 0,75	6.00	4.90	7.20	80.00	14.00	30.00	8.004
M8 x 1	6.00	4.90	7.00	90.00	17.00	35.00	8.005
M10 x 1	7.00	5.50	9.00	90.00	16.00	35.00	10.005
M10 x 1,25	7.00	5.50	8.80	100.00	20.00	39.00	10.006
M12 x 1	9.00	7.00	11.00	100.00	20.00	40.00	12.005
M12 x 1,25	9.00	7.00	10.80	100.00	20.00	40.00	12.006
M12 x 1,5	9.00	7.00	10.50	100.00	20.00	40.00	12.007
M14 x 1,5	11.00	9.00	12.50	100.00	20.00	40.00	14.007
M16 x 1,5	12.00	9.00	14.50	100.00	22.00	44.00	16.007

Taps for UNC threads

Article no. 80702



P	M	K	N	S	H
●	○	○	○	○	○

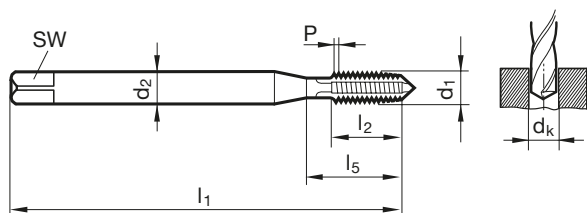

d1	d2 mm	SW mm	dk mm	l1 mm	l2 mm	l5 mm	Code no.
4 - 40	3.50	2.70	2.35	56.00	11.00	18.00	2.845
6 - 32	4.00	3.00	2.85	56.00	12.00	20.00	3.505
8 - 32	4.50	3.40	3.50	63.00	12.00	21.00	4.166
10 - 24	6.00	4.90	3.90	70.00	14.00	25.00	4.826
1/4 - 20	7.00	5.50	5.10	80.00	16.00	30.00	6.350
5/16 - 18	8.00	6.20	6.60	90.00	18.00	35.00	7.938
3/8 - 16	10.00	8.00	8.00	100.00	20.00	39.00	9.525
7/16 - 14	8.00	6.20	9.40	100.00	22.00	42.00	11.113
1/2 - 13	9.00	7.00	10.80	110.00	25.00	49.00	12.700
5/8 - 11	12.00	9.00	13.50	110.00	30.00	53.00	15.875
3/4 - 10	14.00	11.00	16.50	125.00	33.00	62.00	19.050
7/8 - 9	18.00	14.50	19.50	140.00	35.00	62.00	22.225
1 - 8	18.00	14.50	22.25	160.00	38.00	73.00	25.400

Taps for UNC threads

Article no. 80732



P	M	K	N	S	H
•	○		○		

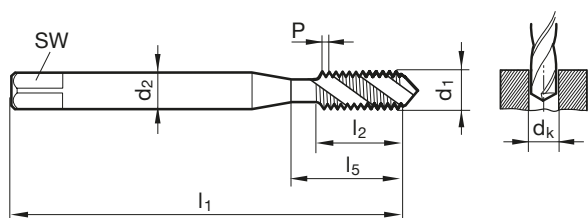

d1	d2 mm	SW mm	dk mm	l1 mm	l2 mm	l5 mm	Code no.
2 - 56	2.80	2.10	1.85	45.00	5.00	14.50	2.184
4 - 40	3.50	2.70	2.35	56.00	7.00	18.00	2.845
6 - 32	4.00	3.00	2.85	56.00	8.00	20.00	3.505
8 - 32	4.50	3.40	3.50	63.00	8.00	21.00	4.166
10 - 24	6.00	4.90	3.90	70.00	11.00	25.00	4.826
1/4 - 20	7.00	5.50	5.10	80.00	13.00	30.00	6.350
5/16 - 18	8.00	6.20	6.60	90.00	14.00	35.00	7.938
3/8 - 16	10.00	8.00	8.00	100.00	16.00	39.00	9.525
7/16 - 14	8.00	6.20	9.40	100.00	18.00	42.00	11.113
1/2 - 13	9.00	7.00	10.80	110.00	20.00	49.00	12.700
9/16 - 12	11.00	9.00	12.20	110.00	21.00	53.00	14.288
5/8 - 11	12.00	9.00	13.50	110.00	24.00	53.00	15.875
3/4 - 10	14.00	11.00	16.50	125.00	25.00	62.00	19.050
7/8 - 9	18.00	14.50	19.50	140.00	28.00	62.00	22.225

Taps for UNC threads

Article no. 80712



P	M	K	N	S	H
•	○	○	•		

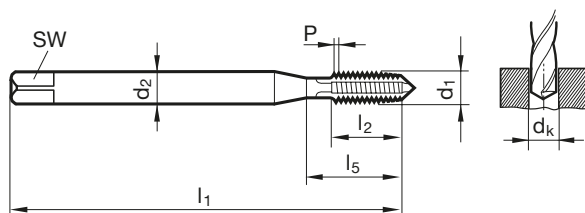

d1	d2 mm	SW mm	dk mm	l1 mm	l2 mm	l5 mm	Code no.
4 - 40	3.50	2.70	2.35	56.00	11.00	18.00	2.845
6 - 32	4.00	3.00	2.85	56.00	12.00	20.00	3.505
8 - 32	4.50	3.40	3.50	63.00	12.00	21.00	4.166
10 - 24	6.00	4.90	3.90	70.00	14.00	25.00	4.826
12 - 24	6.00	4.90	4.50	80.00	16.00	30.00	5.486
1/4 - 20	7.00	5.50	5.10	80.00	16.00	30.00	6.350
5/16 - 18	8.00	6.20	6.60	90.00	18.00	35.00	7.938
3/8 - 16	10.00	8.00	8.00	100.00	20.00	39.00	9.525
1/2 - 13	9.00	7.00	10.80	110.00	25.00	49.00	12.700
5/8 - 11	12.00	9.00	13.50	110.00	30.00	53.00	15.875
3/4 - 10	14.00	11.00	16.50	125.00	33.00	62.00	19.050
7/8 - 9	18.00	14.50	19.50	140.00	35.00	62.00	22.225
1 - 8	18.00	14.50	22.25	160.00	38.00	73.00	25.400

Taps for UNC threads

Article no. 80742



P	M	K	N	S	H
●	○	○	○		

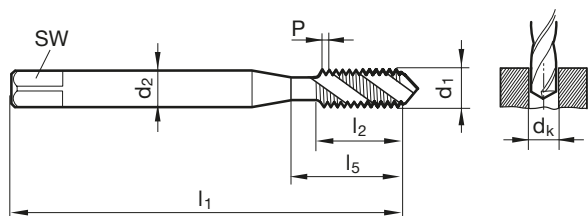

d1	d2 mm	SW mm	dk mm	l1 mm	l2 mm	l5 mm	Code no.
6 - 32	4.00	3.00	2.85	56.00	8.00	20.00	3.505
8 - 32	4.50	3.40	3.50	63.00	8.00	21.00	4.166
10 - 24	6.00	4.90	3.90	70.00	11.00	25.00	4.826
1/4 - 20	7.00	5.50	5.10	80.00	13.00	30.00	6.350
5/16 - 18	8.00	6.20	6.60	90.00	14.00	35.00	7.938
3/8 - 16	10.00	8.00	8.00	100.00	16.00	39.00	9.525
7/16 - 14	8.00	6.20	9.40	100.00	18.00	42.00	11.113
1/2 - 13	9.00	7.00	10.80	110.00	20.00	49.00	12.700
5/8 - 11	12.00	9.00	13.50	110.00	24.00	53.00	15.875
3/4 - 10	14.00	11.00	16.50	125.00	25.00	62.00	19.050
7/8 - 9	18.00	14.50	19.50	140.00	28.00	62.00	22.225
1 - 8	18.00	14.50	22.25	160.00	32.00	73.00	25.400

Taps for UNC threads

Article no. 80802



P	M	K	N	S	H
•	•	•	•	○	

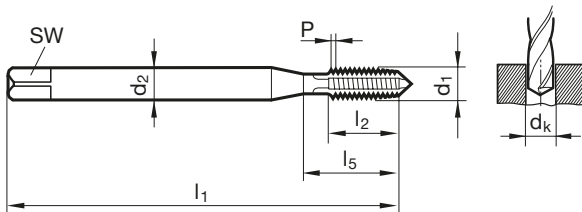

d1	d2 mm	SW mm	dk mm	l1 mm	l2 mm	l5 mm	Code no.
4 - 40	3.50	2.70	2.35	56.00	11.00	18.00	2.845
6 - 32	4.00	3.00	2.85	56.00	12.00	20.00	3.505
8 - 32	4.50	3.40	3.50	63.00	12.00	21.00	4.166
10 - 24	6.00	4.90	3.90	70.00	14.00	25.00	4.826
1/4 - 20	7.00	5.50	5.10	80.00	16.00	30.00	6.350
5/16 - 18	8.00	6.20	6.60	90.00	18.00	35.00	7.938
3/8 - 16	10.00	8.00	8.00	100.00	20.00	39.00	9.525
7/16 - 14	8.00	6.20	9.40	100.00	22.00	42.00	11.113
1/2 - 13	9.00	7.00	10.80	110.00	25.00	49.00	12.700
9/16 - 12	11.00	9.00	12.20	110.00	28.00	53.00	14.288
5/8 - 11	12.00	9.00	13.50	110.00	30.00	53.00	15.875
3/4 - 10	14.00	11.00	16.50	125.00	33.00	62.00	19.050
7/8 - 9	18.00	14.50	19.50	140.00	35.00	62.00	22.225
1 - 8	18.00	14.50	22.25	160.00	38.00	73.00	25.400

Taps for UNC threads

Article no. 80832



P	M	K	N	S	H
•	•	•	•	○	

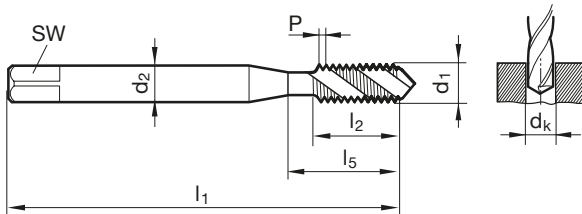

d1	d2 mm	SW mm	dk mm	l1 mm	l2 mm	l5 mm	Code no.
4 - 40	3.50	2.70	2.35	56.00	7.00	18.00	2.845
6 - 32	4.00	3.00	2.85	56.00	8.00	20.00	3.505
8 - 32	4.50	3.40	3.50	63.00	8.00	21.00	4.166
10 - 24	6.00	4.90	3.90	70.00	11.00	25.00	4.826
1/4 - 20	7.00	5.50	5.10	80.00	13.00	30.00	6.350
5/16 - 18	8.00	6.20	6.60	90.00	14.00	35.00	7.938
3/8 - 16	10.00	8.00	8.00	100.00	16.00	39.00	9.525
7/16 - 14	8.00	6.20	9.40	100.00	18.00	42.00	11.113
1/2 - 13	9.00	7.00	10.80	110.00	20.00	49.00	12.700
9/16 - 12	11.00	9.00	12.20	110.00	21.00	53.00	14.288
5/8 - 11	12.00	9.00	13.50	110.00	24.00	53.00	15.875
3/4 - 10	14.00	11.00	16.50	125.00	25.00	62.00	19.050
7/8 - 9	18.00	14.50	19.50	140.00	28.00	62.00	22.225



Taps for UNC threads

Article no. 80752



P	M	K	N	S	H
		•			

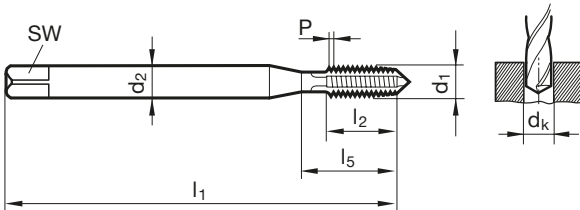

d1	d2 mm	SW mm	dk mm	l1 mm	l2 mm	l5 mm	Code no.
4 - 40	3.50	2.70	2.35	56.00	11.00	18.00	2.845
6 - 32	4.00	3.00	2.85	56.00	12.00	20.00	3.505
8 - 32	4.50	3.40	3.50	63.00	12.00	21.00	4.166
10 - 24	6.00	4.90	3.90	70.00	14.00	25.00	4.826
1/4 - 20	7.00	5.50	5.10	80.00	16.00	30.00	6.350
5/16 - 18	8.00	6.20	6.60	90.00	18.00	35.00	7.938
3/8 - 16	10.00	8.00	8.00	100.00	20.00	39.00	9.525
7/16 - 14	8.00	6.20	9.40	100.00	22.00	42.00	11.113
1/2 - 13	9.00	7.00	10.80	110.00	25.00	49.00	12.700
9/16 - 12	11.00	9.00	12.20	110.00	28.00	53.00	14.288
5/8 - 11	12.00	9.00	13.50	110.00	30.00	53.00	15.875
3/4 - 10	14.00	11.00	16.50	125.00	33.00	62.00	19.050
7/8 - 9	18.00	14.50	19.50	140.00	35.00	62.00	22.225
1 - 8	18.00	14.50	22.25	160.00	38.00	73.00	25.400

Taps for UNF threads

Article no. 80703



P	M	K	N	S	H
•	○	○	○		

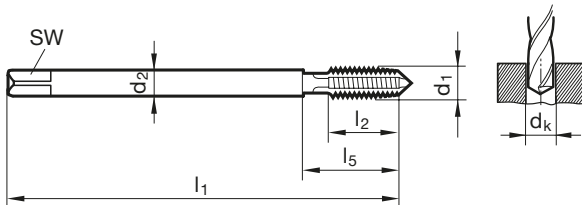

d1	d2 mm	SW mm	dk mm	l1 mm	l2 mm	l5 mm	Code no.
4 - 48	2.20	1.80	2.40	56.00	10.00	18.00	2.845
6 - 40	2.50	2.10	2.95	56.00	11.00	20.00	3.505
10 - 32	3.50	2.70	4.10	70.00	14.00	25.00	4.826
1/4 - 28	4.50	3.40	5.50	80.00	16.00	30.00	6.350
3/8 - 24	7.00	5.50	8.50	90.00	18.00	35.00	9.525
5/8 - 18	12.00	9.00	14.50	110.00	22.00	53.00	15.875
7/8 - 14	18.00	14.50	20.40	140.00	25.00	62.00	22.225
1 - 12	18.00	14.50	23.25	160.00	28.00	73.00	25.400

Taps for UNF threads

Article no. 80733



P	M	K	N	S	H
●	○	○	○		

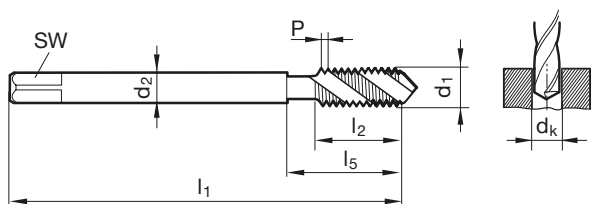

d1	d2 mm	SW mm	dk mm	l1 mm	l2 mm	l5 mm	Code no.
3 - 56	1.80	1.40	2.15	50.00	5.00	14.50	2.515
4 - 48	2.20	1.80	2.40	56.00	6.00	18.00	2.845
6 - 40	2.50	2.10	2.95	56.00	6.50	20.00	3.505
8 - 36	2.80	2.10	3.50	63.00	7.00	21.00	4.166
10 - 32	3.50	2.70	4.10	70.00	8.50	25.00	4.826
1/4 - 28	4.50	3.40	5.50	80.00	9.50	30.00	6.350
3/8 - 24	7.00	5.50	8.50	90.00	11.50	35.00	9.525
7/16 - 20	8.00	6.20	9.90	100.00	13.00	42.00	11.113
1/2 - 20	9.00	7.00	11.50	100.00	13.00	40.00	12.700
5/8 - 18	12.00	9.00	14.50	100.00	15.00	44.00	15.875
7/8 - 14	18.00	14.50	20.40	125.00	19.00	44.00	22.225
1 - 12	18.00	14.50	23.25	140.00	22.00	50.00	25.400

Taps for UNF threads

Article no. 80713



P	M	K	N	S	H
•	○	○	•		

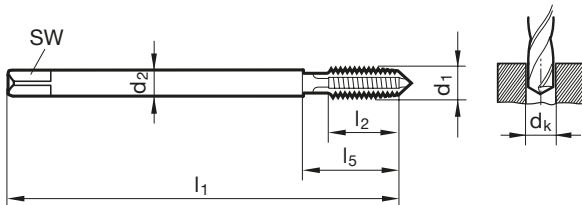

d1	d2 mm	SW mm	dk mm	l1 mm	l2 mm	l5 mm	Code no.
4 - 48	2.20	1.80	2.40	56.00	10.00	18.00	2.845
6 - 40	2.50	2.10	2.95	56.00	11.00	20.00	3.505
10 - 32	3.50	2.70	4.10	70.00	14.00	25.00	4.826
1/4 - 28	4.50	3.40	5.50	80.00	16.00	30.00	6.350
3/8 - 24	7.00	5.50	8.50	90.00	18.00	35.00	9.525
5/8 - 18	12.00	9.00	14.50	100.00	22.00	44.00	15.875
7/8 - 14	18.00	14.50	20.40	125.00	25.00	44.00	22.225
1 - 12	18.00	14.50	23.25	140.00	28.00	50.00	25.400

Taps for UNF threads

Article no. 80743



P	M	K	N	S	H
•	○	○			

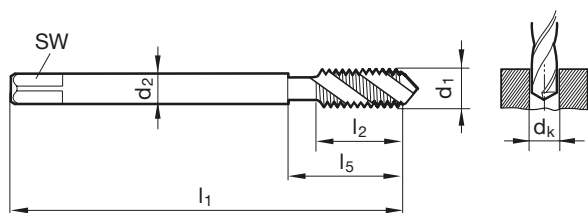

d1	d2 mm	SW mm	dk mm	l1 mm	l2 mm	l5 mm	Code no.
6 - 40	2.50	2.10	2.95	56.00	6.50	20.00	3.505
8 - 36	2.80	2.10	3.50	63.00	7.00	21.00	4.166
10 - 32	3.50	2.70	4.10	70.00	8.50	25.00	4.826
1/4 - 28	4.50	3.40	5.50	80.00	9.50	30.00	6.350
5/16 - 24	6.00	4.90	6.90	90.00	11.50	35.00	7.938
3/8 - 24	7.00	5.50	8.50	90.00	11.50	35.00	9.525
7/16 - 20	8.00	6.20	9.90	100.00	13.00	42.00	11.113
1/2 - 20	9.00	7.00	11.50	100.00	13.00	40.00	12.700
5/8 - 18	12.00	9.00	14.50	100.00	15.00	44.00	15.875
7/8 - 14	18.00	14.50	20.40	125.00	19.00	44.00	22.225

Taps for UNF threads

Article no. 80803



P	M	K	N	S	H
•	•	•	•	○	

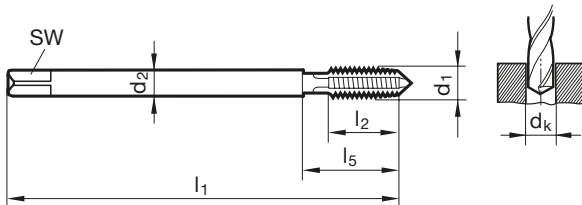

d1	d2 mm	SW mm	dk mm	l1 mm	l2 mm	l5 mm	Code no.
4 - 48	3.50	2.70	2.40	56.00	10.00	18.00	2.845
6 - 40	4.00	3.00	2.95	56.00	11.00	20.00	3.505
8 - 36	4.50	3.40	3.50	63.00	12.00	21.00	4.166
10 - 32	6.00	4.90	4.10	70.00	14.00	25.00	4.826
1/4 - 28	7.00	5.50	5.50	80.00	16.00	30.00	6.350
5/16 - 24	8.00	6.20	6.90	90.00	17.00	35.00	7.938
3/8 - 24	10.00	8.00	8.50	90.00	18.00	35.00	9.525
7/16 - 20	8.00	6.20	9.90	100.00	22.00	42.00	11.113
5/8 - 18	12.00	9.00	14.50	100.00	22.00	44.00	15.875
7/8 - 14	18.00	14.50	20.40	125.00	25.00	44.00	22.225
1 - 12	18.00	14.50	23.25	140.00	28.00	50.00	25.400

Taps for UNF threads

Article no. 80833



P	M	K	N	S	H
•	•	•	•	○	

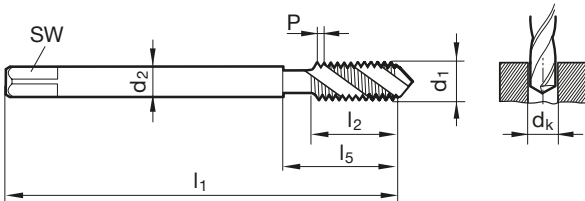

d1	d2 mm	SW mm	dk mm	l1 mm	l2 mm	l5 mm	Code no.
10 - 32	6.00	4.90	4.10	70.00	8.50	25.00	4.826
12 - 28	6.00	4.90	4.60	80.00	9.50	30.00	5.486
1/4 - 28	7.00	5.50	5.50	80.00	9.50	30.00	6.350
5/16 - 24	8.00	6.20	6.90	90.00	11.50	35.00	7.938
3/8 - 24	10.00	8.00	8.50	90.00	11.50	35.00	9.525
7/16 - 20	8.00	6.20	9.90	100.00	13.00	42.00	11.113
1/2 - 20	9.00	7.00	11.50	100.00	13.00	40.00	12.700
5/8 - 18	12.00	9.00	14.50	100.00	15.00	44.00	15.875
7/8 - 14	18.00	14.50	20.40	125.00	19.00	44.00	22.225
1 - 12	18.00	14.50	23.25	140.00	22.00	50.00	25.400



Taps for UNF threads

Article no. 80753



P	M	K	N	S	H
		•			

HSS-E

TG 100 GG
2B
~DIN 374

Cyl
C

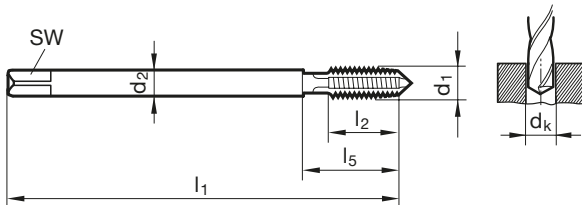

d1	d2 mm	SW mm	dk mm	l1 mm	l2 mm	l5 mm	Code no.
4 - 48	2.20	1.80	2.40	56.00	10.00	18.00	2.845
6 - 40	2.50	2.10	2.95	56.00	11.00	20.00	3.505
8 - 36	2.80	2.10	3.50	63.00	12.00	21.00	4.166
10 - 32	3.50	2.70	4.10	70.00	14.00	25.00	4.826
1/4 - 28	4.50	3.40	5.50	80.00	16.00	30.00	6.350
5/16 - 24	6.00	4.90	6.90	90.00	17.00	35.00	7.938
3/8 - 24	7.00	5.50	8.50	90.00	18.00	35.00	9.525
7/16 - 20	8.00	6.20	9.90	100.00	22.00	42.00	11.113
1/2 - 20	9.00	7.00	11.50	100.00	20.00	40.00	12.700
9/16 - 18	11.00	9.00	12.90	100.00	22.00	40.00	14.288
3/4 - 16	14.00	11.00	17.50	110.00	25.00	44.00	19.050
7/8 - 14	18.00	14.50	20.40	125.00	25.00	44.00	22.225
1 - 12	18.00	14.50	23.25	140.00	28.00	50.00	25.400

Taps for BSP threads

Article no. 80704



P	M	K	N	S	H
•	○	○	○		

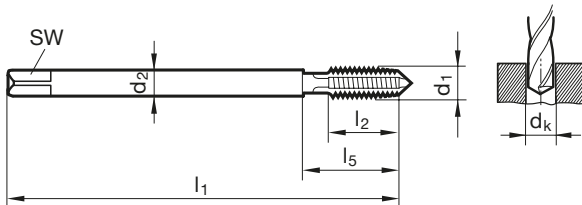

d1	P G/inch	d2 mm	SW mm	dk mm	l1 mm	l2 mm	l5 mm	Code no.
G1/8	28.00	7.00	5.50	8.80	90.00	18.00	35.00	9.728
G1/4	19.00	11.00	9.00	11.80	100.00	20.00	40.00	13.157
G3/8	19.00	12.00	9.00	15.25	100.00	22.00	44.00	16.662
G1/2	14.00	16.00	12.00	19.00	125.00	25.00	44.00	20.955
G3/4	14.00	20.00	16.00	24.50	140.00	28.00	53.00	26.441
G1	11.00	25.00	20.00	30.75	160.00	30.00	56.00	33.249
G1 1/4	11.00	32.00	24.00	39.50	170.00	30.00	57.00	41.910
G1 1/2	11.00	36.00	29.00	45.25	190.00	32.00	60.00	47.803
G2	11.00	45.00	35.00	57.00	220.00	40.00	95.00	59.614

Taps for BSP threads

Article no. 80734



P	M	K	N	S	H
●	○	○	○		

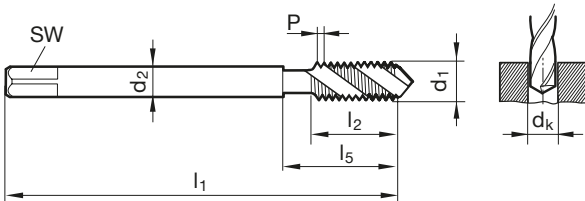

d1	P G/inch	d2 mm	SW mm	dk mm	l1 mm	l2 mm	l5 mm	Code no.
G1/16	28.00	6.00	4.90	6.80	90.00	11.00	30.00	7.723
G1/8	28.00	7.00	5.50	8.80	90.00	11.00	35.00	9.728
G1/4	19.00	11.00	9.00	11.80	100.00	14.00	40.00	13.157
G3/8	19.00	12.00	9.00	15.25	100.00	14.00	44.00	16.662
G1/2	14.00	16.00	12.00	19.00	125.00	18.00	44.00	20.955
G3/4	14.00	20.00	16.00	24.50	140.00	20.00	53.00	26.441
G1	11.00	25.00	20.00	30.75	160.00	24.00	56.00	33.249
G1 1/4	11.00	32.00	24.00	39.50	170.00	25.00	57.00	41.910
G1 1/2	11.00	36.00	29.00	45.25	190.00	27.00	60.00	47.803
G2	11.00	45.00	35.00	57.00	220.00	32.00	95.00	59.614

Taps for BSP threads

Article no. 80714



P	M	K	N	S	H
•	○	○	•		

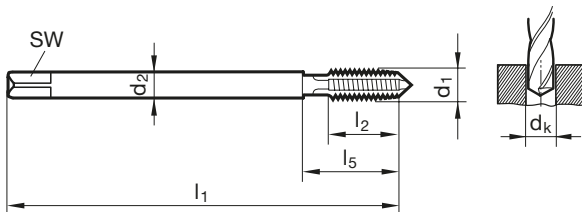

d1	P	d2	SW	dk	l1	l2	l5	Code no.
	G/inch	mm	mm	mm	mm	mm	mm	
G1/16	28.00	6.00	4.90	6.80	90.00	18.00	30.00	7.723
G1/8	28.00	7.00	5.50	8.80	90.00	18.00	35.00	9.728
G1/4	19.00	11.00	9.00	11.80	100.00	20.00	40.00	13.157
G3/8	19.00	12.00	9.00	15.25	100.00	22.00	44.00	16.662
G1/2	14.00	16.00	12.00	19.00	125.00	25.00	44.00	20.955
G3/4	14.00	20.00	16.00	24.50	140.00	28.00	53.00	26.441
G7/8	14.00	22.00	18.00	28.25	150.00	28.00	53.00	30.201

Taps for BSP threads

Article no. 80744



P	M	K	N	S	H
•	○	○	○		

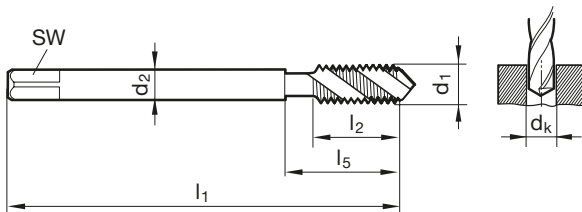

d1	P	d2	SW	dk	l1	l2	l5	Code no.
	G/inch	mm	mm	mm	mm	mm	mm	
G1/8	28.00	7.00	5.50	8.80	90.00	11.00	35.00	9.728
G1/4	19.00	11.00	9.00	11.80	100.00	14.00	40.00	13.157
G3/8	19.00	12.00	9.00	15.25	100.00	14.00	44.00	16.662
G1/2	14.00	16.00	12.00	19.00	125.00	18.00	44.00	20.955
G3/4	14.00	20.00	16.00	24.50	140.00	20.00	53.00	26.441
G1	11.00	25.00	20.00	30.75	160.00	24.00	56.00	33.249

Taps for BSP threads

Article no. 80804



P	M	K	N	S	H
•	•	•	•	○	

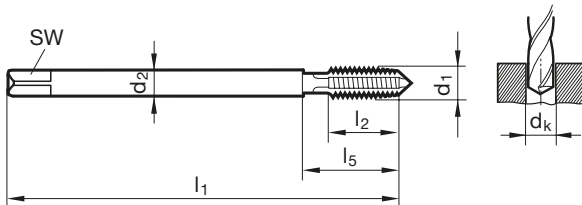

d1	P G/inch	d2 mm	SW mm	dk mm	l1 mm	l2 mm	l5 mm	Code no.
G1/8	28.00	7.00	5.50	8.80	90.00	18.00	35.00	9.728
G1/4	19.00	11.00	9.00	11.80	100.00	20.00	40.00	13.157
G3/8	19.00	12.00	9.00	15.25	100.00	22.00	44.00	16.662
G1/2	14.00	16.00	12.00	19.00	125.00	25.00	44.00	20.955
G5/8	14.00	18.00	14.50	21.00	125.00	25.00	48.00	22.911
G3/4	14.00	20.00	16.00	24.50	140.00	28.00	53.00	26.441
G7/8	14.00	22.00	18.00	28.25	150.00	28.00	53.00	30.201
G1	11.00	25.00	20.00	30.75	160.00	30.00	56.00	33.249

Taps for BSP threads

Article no. 80834



P	M	K	N	S	H
•	•	•	•	○	

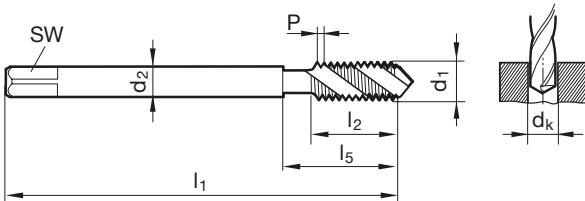

d1	P G/inch	d2 mm	SW mm	dk mm	l1 mm	l2 mm	l5 mm	Code no.
G1/16	28.00	6.00	4.90	6.80	90.00	11.00	30.00	7.723
G1/8	28.00	7.00	5.50	8.80	90.00	11.00	35.00	9.728
G1/4	19.00	11.00	9.00	11.80	100.00	14.00	40.00	13.157
G3/8	19.00	12.00	9.00	15.25	100.00	14.00	44.00	16.662
G1/2	14.00	16.00	12.00	19.00	125.00	18.00	44.00	20.955
G5/8	14.00	18.00	14.50	21.00	125.00	18.00	48.00	22.911
G3/4	14.00	20.00	16.00	24.50	140.00	20.00	53.00	26.441
G7/8	14.00	22.00	18.00	28.25	150.00	22.00	53.00	30.201
G1	11.00	25.00	20.00	30.75	160.00	24.00	56.00	33.249

Taps for BSP threads

Article no. 80812



P	M	K	N	S	H
•	•	•	•	○	

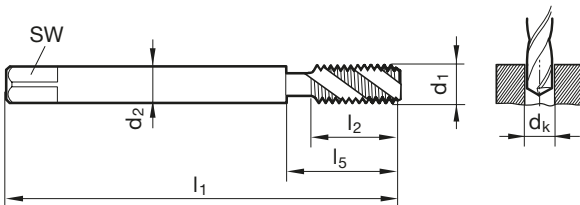

d1	P	d2	SW	dk	l1	l2	l5	Code no.
	G/inch	mm	mm	mm	mm	mm	mm	
G1/16	28.00	6.00	4.90	6.80	90.00	11.00	30.00	7.723
G1/8	28.00	7.00	5.50	8.80	90.00	11.00	35.00	9.728
G1/4	19.00	11.00	9.00	11.80	100.00	14.00	40.00	13.157
G3/8	19.00	12.00	9.00	15.25	100.00	14.00	44.00	16.662
G1/2	14.00	16.00	12.00	19.00	125.00	18.00	44.00	20.955
G5/8	14.00	18.00	14.50	21.00	125.00	18.00	48.00	22.911
G3/4	14.00	20.00	16.00	24.50	140.00	20.00	53.00	26.441
G7/8	14.00	22.00	18.00	28.25	150.00	22.00	53.00	30.201
G1	11.00	25.00	20.00	30.75	160.00	24.00	56.00	33.249

Taps for BSP threads

Article no. 80784



P	M	K	N	S	H
•	•	•	•	○	



long version

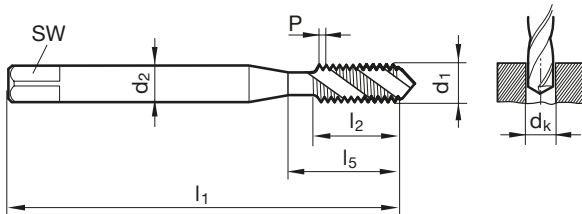

d1	P	d2	SW	dk	l1	l2	l5	Code no.
	G/inch	mm	mm	mm	mm	mm	mm	
G1/8	28.00	7.00	5.50	8.80	200.00	16.00	140.00	9.728
G1/4	19.00	11.00	9.00	11.80	220.00	20.00	160.00	13.157
G3/8	19.00	12.00	9.00	15.25	250.00	25.00	160.00	16.662
G1/2	14.00	16.00	12.00	19.00	280.00	27.00	217.00	20.955



Taps for BSP threads

Article no. 80754



P	M	K	N	S	H
		•			

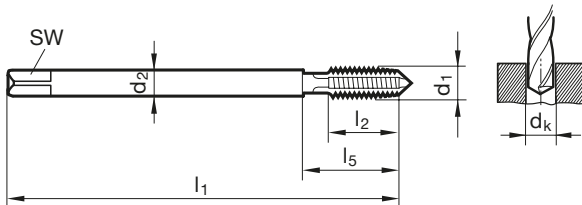

d1	P	d2	SW	dk	l1	l2	l5	Code no.
	G/inch	mm	mm	mm	mm	mm	mm	
G1/16	28.00	6.00	4.90	6.80	90.00	18.00	30.00	7.723
G1/8	28.00	7.00	5.50	8.80	90.00	18.00	35.00	9.728
G1/4	19.00	11.00	9.00	11.80	100.00	20.00	40.00	13.157
G3/8	19.00	12.00	9.00	15.25	100.00	22.00	44.00	16.662
G1/2	14.00	16.00	12.00	19.00	125.00	25.00	44.00	20.955
G5/8	14.00	18.00	14.50	21.00	125.00	25.00	48.00	22.911
G3/4	14.00	20.00	16.00	24.50	140.00	28.00	53.00	26.441
G7/8	14.00	22.00	18.00	28.25	150.00	28.00	53.00	30.201
G1	11.00	25.00	20.00	30.75	160.00	30.00	56.00	33.249
G1 1/8	11.00	28.00	22.00	35.50	170.00	30.00	56.00	37.897
G1 1/4	11.00	32.00	24.00	39.50	170.00	30.00	57.00	41.910
G1 3/8	11.00	36.00	29.00	41.75	180.00	32.00	60.00	44.323
G1 1/2	11.00	36.00	29.00	45.25	190.00	32.00	60.00	47.803
G1 3/4	11.00	40.00	32.00	51.00	190.00	40.00	93.00	53.746
G2	11.00	45.00	35.00	57.00	220.00	40.00	95.00	59.614

Fluteless taps for ISO metric threads

Article no. 80900



P	M	K	N	S	H
•	○	•	•	○	

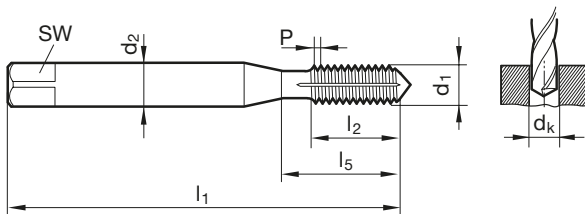

d1	P	d2	SW	dk	l1	l2	l5	Code no.
mm	mm	mm	mm	mm	mm	mm	mm	
M3	0.50	3.50	2.70	2.80	56.00	10.00	18.00	3.000
M3,5	0.60	4.00	3.00	3.25	56.00	12.00	20.00	3.500
M4	0.70	4.50	3.40	3.70	63.00	12.00	21.00	4.000
M5	0.80	6.00	4.90	4.65	70.00	14.00	25.00	5.000
M6	1.00	6.00	4.90	5.55	80.00	16.00	30.00	6.000
M8	1.25	8.00	6.20	7.40	90.00	17.00	35.00	8.000
M10	1.50	10.00	8.00	9.30	100.00	20.00	39.00	10.000
M12	1.75	9.00	7.00	11.20	110.00	24.00	49.00	12.000
M14	2.00	11.00	9.00	13.10	110.00	26.00	53.00	14.000
M16	2.00	12.00	9.00	15.10	110.00	26.00	54.00	16.000
M18	2.50	14.00	11.00	16.90	125.00	30.00	62.00	18.000
M20	2.50	16.00	12.00	18.90	140.00	32.00	62.00	20.000
M22	2.50	18.00	14.50	20.90	140.00	32.00	62.00	22.000
M24	3.00	18.00	14.50	22.70	160.00	36.00	73.00	24.000
M27	3.00	20.00	16.00	25.70	160.00	36.00	73.00	27.000
M30	3.50	22.00	18.00	28.50	180.00	40.00	85.00	30.000
M33	3.50	25.00	20.00	31.50	180.00	40.00	91.00	33.000
M36	4.00	28.00	22.00	34.30	200.00	50.00	102.00	36.000
M39	4.00	32.00	24.00	37.30	200.00	50.00	107.00	39.000

Fluteless taps for ISO metric threads

Article no. 80920



P	M	K	N	S	H
•	•	•	•	•	

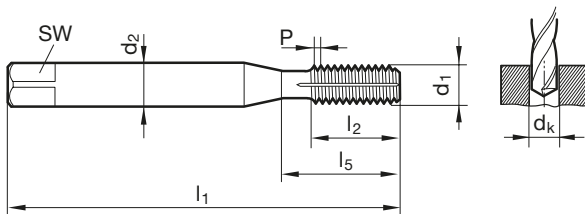

d1	P	d2	SW	dk	l1	l2	l5	Code no.
mm	mm	mm	mm	mm	mm	mm	mm	
M1	0.25	2.50	2.10	0.90	40.00	4.00	4.00	1.000
M1,2	0.25	2.50	2.10	1.10	40.00	4.80	4.80	1.200
M1,4	0.30	2.50	2.10	1.25	40.00	5.60	5.60	1.400
M1,6	0.35	2.50	2.10	1.45	40.00	6.40	6.40	1.600
M1,7	0.35	2.50	2.10	1.55	40.00	6.80	6.80	1.700
M1,8	0.35	2.50	2.10	1.65	40.00	7.30	7.30	1.800
M2	0.40	2.80	2.10	1.85	45.00	8.00	13.50	2.000
M2,5	0.45	2.80	2.10	2.30	50.00	9.00	14.50	2.500
M3	0.50	3.50	2.70	2.80	56.00	10.00	18.00	3.000
M4	0.70	4.50	3.40	3.70	63.00	12.00	21.00	4.000
M5	0.80	6.00	4.90	4.65	70.00	14.00	25.00	5.000
M6	1.00	6.00	4.90	5.55	80.00	16.00	30.00	6.000
M8	1.25	8.00	6.20	7.40	90.00	17.00	35.00	8.000
M10	1.50	10.00	8.00	9.30	100.00	20.00	39.00	10.000
M12	1.75	9.00	7.00	11.20	110.00	24.00	49.00	12.000
M14	2.00	11.00	9.00	13.10	110.00	26.00	53.00	14.000
M16	2.00	12.00	9.00	15.10	110.00	26.00	54.00	16.000
M20	2.50	16.00	12.00	18.90	140.00	32.00	62.00	20.000

Fluteless taps for ISO metric threads

Article no. 80925



P	M	K	N	S	H
•	○	•	•	○	

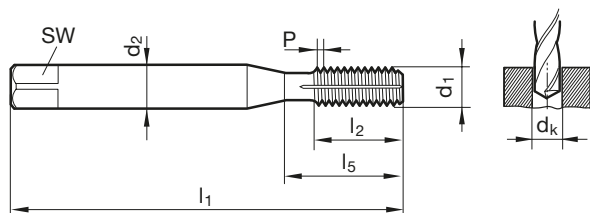

d1	P	d2	SW	dk	l1	l2	l5	Code no.
mm	mm	mm	mm	mm	mm	mm	mm	
M2	0.40	2.80	2.10	1.85	45.00	8.00	13.50	2.000
M2,5	0.45	2.80	2.10	2.30	50.00	9.00	14.50	2.500
M3	0.50	3.50	2.70	2.80	56.00	10.00	18.00	3.000
M4	0.70	4.50	3.40	3.70	63.00	12.00	21.00	4.000
M5	0.80	6.00	4.90	4.65	70.00	14.00	25.00	5.000
M6	1.00	6.00	4.90	5.55	80.00	16.00	30.00	6.000
M8	1.25	8.00	6.20	7.40	90.00	17.00	35.00	8.000
M10	1.50	10.00	8.00	9.30	100.00	20.00	39.00	10.000
M12	1.75	9.00	7.00	11.20	110.00	24.00	49.00	12.000
M14	2.00	11.00	9.00	13.10	110.00	26.00	53.00	14.000
M16	2.00	12.00	9.00	15.10	110.00	26.00	54.00	16.000
M20	2.50	16.00	12.00	18.90	140.00	32.00	62.00	20.000

Fluteless taps for ISO metric fine threads

Article no. 80901



P	M	K	N	S	H
•	○	•	•	○	

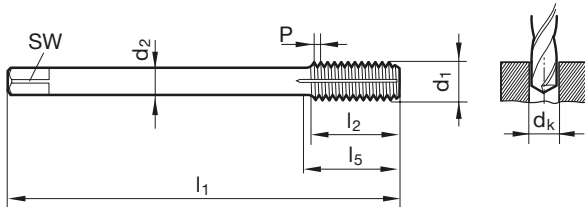

d1	d2 mm	SW mm	dk mm	l1 mm	l2 mm	l5 mm	Code no.
M6 x 0,75	4.50	3.40	5.65	80.00	13.00	30.00	6.004
M8 x 0,75	6.00	4.90	7.65	80.00	14.00	30.00	8.004
M8 x 1	6.00	4.90	7.55	90.00	17.00	35.00	8.005
M10 x 1	7.00	5.50	9.55	90.00	16.00	35.00	10.005
M10 x 1,25	7.00	5.50	9.40	100.00	20.00	39.00	10.006
M12 x 1	9.00	7.00	11.55	100.00	20.00	40.00	12.005
M12 x 1,25	9.00	7.00	11.40	100.00	20.00	40.00	12.006
M12 x 1,5	9.00	7.00	11.30	100.00	20.00	40.00	12.007
M14 x 1	11.00	9.00	13.55	100.00	20.00	40.00	14.005
M14 x 1,5	11.00	9.00	13.30	100.00	20.00	40.00	14.007
M16 x 1	12.00	9.00	15.55	100.00	22.00	44.00	16.005
M16 x 1,5	12.00	9.00	15.30	100.00	22.00	44.00	16.007
M18 x 1	14.00	11.00	17.55	110.00	25.00	44.00	18.005
M18 x 1,5	14.00	11.00	17.30	110.00	25.00	44.00	18.007
M20 x 1	16.00	12.00	19.55	125.00	25.00	44.00	20.005
M20 x 1,5	16.00	12.00	19.30	125.00	25.00	44.00	20.007
M22 x 1,5	18.00	14.50	21.30	125.00	25.00	44.00	22.007
M24 x 1,5	18.00	14.50	23.30	140.00	28.00	48.00	24.007

Fluteless taps for ISO metric fine threads

Article no. 80921



P	M	K	N	S	H
•	○	•	•	○	

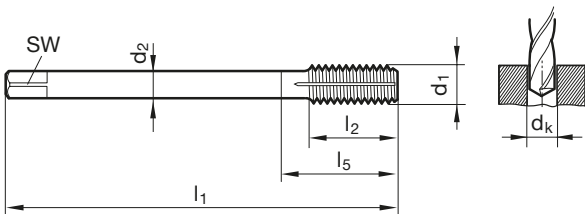

d1	d2 mm	SW mm	dk mm	l1 mm	l2 mm	l5 mm	Code no.
M8 x 1	6.00	4.90	7.55	90.00	17.00	35.00	8.005
M10 x 1	7.00	5.50	9.55	90.00	16.00	35.00	10.005
M10 x 1,25	7.00	5.50	9.40	100.00	20.00	39.00	10.006
M12 x 1,25	9.00	7.00	11.40	100.00	20.00	40.00	12.006
M12 x 1,5	9.00	7.00	11.30	100.00	20.00	40.00	12.007
M14 x 1,25	11.00	9.00	13.40	100.00	20.00	40.00	14.006
M14 x 1,5	11.00	9.00	13.30	100.00	20.00	40.00	14.007
M16 x 1,5	12.00	9.00	15.30	100.00	22.00	44.00	16.007
M20 x 1,5	16.00	12.00	19.30	125.00	25.00	44.00	20.007

Fluteless taps for UNC threads

Article no. 80902



P	M	K	N	S	H
•					

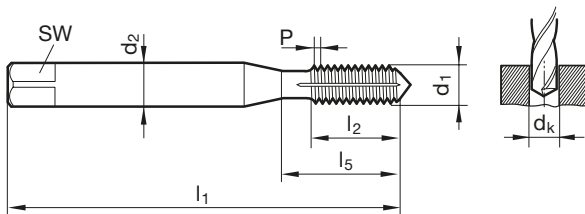

d1	d2 mm	SW mm	dk mm	l1 mm	l2 mm	l5 mm	Code no.
4 - 40	3.50	2.70	2.55	56.00	11.00	18.00	2.845
5 - 40	3.50	2.70	2.90	56.00	11.00	18.00	3.175
6 - 32	4.00	3.00	3.15	56.00	12.00	20.00	3.505
8 - 32	4.50	3.40	3.80	63.00	12.00	21.00	4.166
10 - 24	6.00	4.90	4.35	70.00	14.00	25.00	4.826
12 - 24	6.00	4.90	5.00	80.00	16.00	30.00	5.486
1/4 - 20	7.00	5.50	5.75	80.00	16.00	30.00	6.350
5/16 - 18	8.00	6.20	7.30	90.00	18.00	35.00	7.938
3/8 - 16	10.00	8.00	8.80	100.00	20.00	39.00	9.525
7/16 - 14	8.00	6.20	10.30	100.00	22.00	42.00	11.113
1/2 - 13	9.00	7.00	11.80	110.00	25.00	49.00	12.700
9/16 - 12	11.00	9.00	13.30	110.00	28.00	53.00	14.288
5/8 - 11	12.00	9.00	14.80	110.00	30.00	53.00	15.875
3/4 - 10	14.00	11.00	17.90	125.00	33.00	62.00	19.050

Fluteless taps for UNC threads

Article no. 80922



P	M	K	N	S	H
•	○	•	•	○	

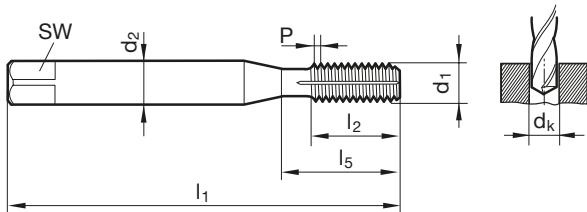

d1	d2 mm	SW mm	dk mm	l1 mm	l2 mm	l5 mm	Code no.
4 - 40	3.50	2.70	2.55	56.00	11.00	18.00	2.845
6 - 32	4.00	3.00	3.15	56.00	10.50	20.00	3.505
8 - 32	4.50	3.40	3.80	63.00	12.00	21.00	4.166
10 - 24	6.00	4.90	4.35	70.00	14.00	25.00	4.826
12 - 24	6.00	4.90	5.00	80.00	16.00	30.00	5.486
1/4 - 20	7.00	5.50	5.75	80.00	16.00	30.00	6.350
5/16 - 18	8.00	6.20	7.30	90.00	18.00	35.00	7.938
3/8 - 16	10.00	8.00	8.80	100.00	20.00	39.00	9.525
7/16 - 14	8.00	6.20	10.30	100.00	22.00	42.00	11.113
1/2 - 13	9.00	7.00	11.80	110.00	25.00	49.00	12.700
9/16 - 12	11.00	9.00	13.30	110.00	28.00	53.00	14.288
5/8 - 11	12.00	9.00	14.80	110.00	30.00	53.00	15.875
3/4 - 10	14.00	11.00	17.90	125.00	33.00	62.00	19.050

Fluteless taps for UNF threads

Article no. 80903



P	M	K	N	S	H
•	○	•	•	○	

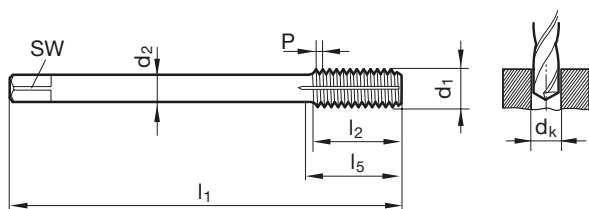

d1	d2 mm	SW mm	dk mm	l1 mm	l2 mm	l5 mm	Code no.
4 - 48	3.50	2.70	2.60	56.00	10.00	18.00	2.845
5 - 44	3.50	2.70	2.90	56.00	10.00	18.00	3.175
6 - 40	4.00	3.00	3.20	56.00	11.00	20.00	3.505
8 - 36	4.50	3.40	3.85	63.00	12.00	21.00	4.166
10 - 32	6.00	4.90	4.45	70.00	14.00	25.00	4.826
12 - 28	6.00	4.90	5.10	80.00	16.00	30.00	5.486
1/4 - 28	7.00	5.50	5.95	80.00	16.00	30.00	6.350
5/16 - 24	8.00	6.20	7.45	90.00	17.00	35.00	7.938
3/8 - 24	10.00	8.00	9.05	100.00	18.00	39.00	9.525
7/16 - 20	8.00	6.20	10.55	100.00	22.00	42.00	11.113
1/2 - 20	9.00	7.00	12.10	100.00	20.00	40.00	12.700
9/16 - 18	11.00	9.00	13.65	100.00	22.00	40.00	14.288
5/8 - 18	12.00	9.00	15.25	100.00	22.00	44.00	15.875
3/4 - 16	14.00	11.00	18.35	110.00	25.00	44.00	19.050

Fluteless taps for UNF threads

Article no. 80923



P	M	K	N	S	H
•	○	•	•	○	

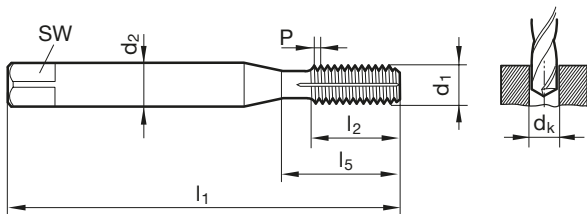

d1	d2 mm	SW mm	dk mm	l1 mm	l2 mm	l5 mm	Code no.
4 - 48	3.50	2.70	2.60	56.00	10.00	18.00	2.845
6 - 40	4.00	3.00	3.20	56.00	10.50	20.00	3.505
8 - 36	4.50	3.40	3.85	63.00	12.00	21.00	4.166
10 - 32	6.00	4.90	4.45	70.00	14.00	25.00	4.826
12 - 28	6.00	4.90	5.10	80.00	16.00	30.00	5.486
1/4 - 28	7.00	5.50	5.95	80.00	16.00	30.00	6.350
5/16 - 24	8.00	6.20	7.45	90.00	17.00	35.00	7.938
3/8 - 24	10.00	8.00	9.05	90.00	18.00	35.00	9.525
7/16 - 20	8.00	6.20	10.55	100.00	22.00	42.00	11.113
1/2 - 20	9.00	7.00	12.10	100.00	20.00	40.00	12.700
9/16 - 18	11.00	9.00	13.65	100.00	22.00	40.00	14.288
5/8 - 18	12.00	9.00	15.25	100.00	22.00	44.00	15.875
3/4 - 16	14.00	11.00	18.35	110.00	25.00	44.00	19.050

Fluteless taps for BSP threads

Article no. 80904



P	M	K	N	S	H
•	○	•	•	○	

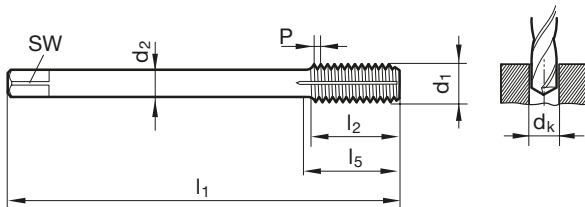

d1	P G/inch	d2 mm	SW mm	dk mm	l1 mm	l2 mm	l5 mm	Code no.
G1/16	28.00	6.00	4.90	7.30	90.00	18.00	30.00	7.723
G1/8	28.00	7.00	5.50	9.30	90.00	18.00	35.00	9.728
G1/4	19.00	11.00	9.00	12.50	100.00	20.00	40.00	13.157
G3/8	19.00	12.00	9.00	16.00	100.00	22.00	44.00	16.662
G1/2	14.00	16.00	12.00	20.00	125.00	25.00	44.00	20.955
G3/4	14.00	20.00	16.00	25.50	140.00	28.00	53.00	26.441

Fluteless taps for BSP threads

Article no. 80924



P	M	K	N	S	H
•	○	•	•	○	

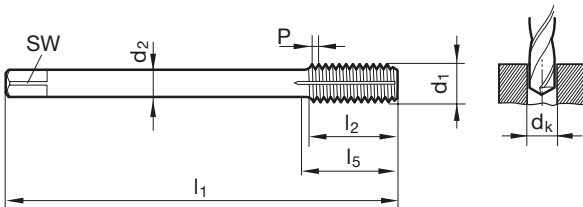

d1	P G/inch	d2 mm	SW mm	dk mm	l1 mm	l2 mm	l5 mm	Code no.
G1/8	28.00	7.00	5.50	9.30	90.00	18.00	35.00	9.728
G1/4	19.00	11.00	9.00	12.50	100.00	20.00	40.00	13.157
G3/8	19.00	12.00	9.00	16.00	100.00	22.00	44.00	16.662
G1/2	14.00	16.00	12.00	20.00	125.00	25.00	44.00	20.955

JIS taps for ISO metric threads

Article no. 80780



P	M	K	N	S	H
●	○	○			

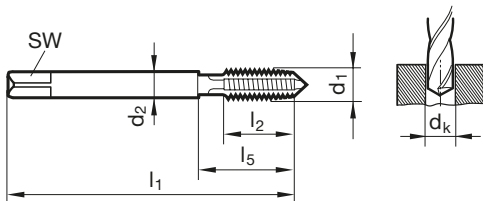

d1	P	Tolerance	d2	SW	dk	l1	l2	l3	Code no.
mm	mm		mm	mm	mm	mm	mm	mm	
M2	0.40	OH2	3.00	2.50	1.60	40.00	8.00	15.00	2.000
M2,5	0.45	OH2	3.00	2.50	2.05	44.00	9.00	16.00	2.500
M3	0.50	OH2	4.00	3.20	2.50	46.00	10.00	19.00	3.000
M4	0.70	OH2	5.00	4.00	3.30	52.00	12.00	20.00	4.000
M5	0.80	OH2	5.50	4.50	4.20	60.00	14.00	24.00	5.000
M6	1.00	OH2	6.00	4.50	5.00	62.00	16.00	29.00	6.000
M8	1.25	OH2	6.20	5.00	6.80	70.00	17.00	37.00	8.000
M10	1.50	OH2	7.00	5.50	8.50	75.00	20.00	41.00	10.000
M12	1.75	OH3	8.50	6.50	10.20	82.00	24.00	48.00	12.000
M14	2.00	OH3	10.50	8.00	12.00	88.00	26.00	48.00	14.000
M16	2.00	OH3	12.50	10.00	14.00	95.00	26.00	52.00	16.000
M18	2.50	OH4	14.00	11.00	15.50	100.00	30.00	55.00	18.000
M20	2.50	OH4	15.00	12.00	17.50	105.00	32.00	58.00	20.000

JIS taps for ISO metric threads

Article no. 80790



P	M	K	N	S	H
•	○	○			

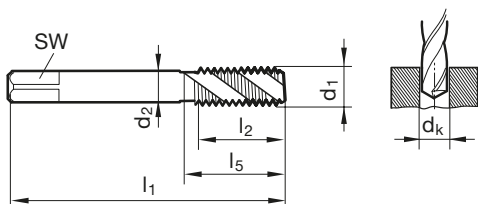

d1	P	Tolerance	d2	SW	dk	l1	l2	l3	Code no.
mm	mm		mm	mm	mm	mm	mm	mm	
M2	0.40	OH2	3.00	2.50	1.60	40.00	4.50	15.00	2.000
M2,5	0.45	OH2	3.00	2.50	2.05	44.00	5.00	16.00	2.500
M3	0.50	OH2	4.00	3.20	2.50	46.00	6.00	19.00	3.000
M4	0.70	OH2	5.00	4.00	3.30	52.00	7.50	20.00	4.000
M5	0.80	OH2	5.50	4.50	4.20	60.00	8.50	24.00	5.000
M6	1.00	OH2	6.00	4.50	5.00	62.00	11.00	29.00	6.000
M8	1.25	OH2	6.20	5.00	6.80	70.00	14.00	37.00	8.000
M10	1.50	OH2	7.00	5.50	8.50	75.00	16.00	41.00	10.000
M12	1.75	OH3	8.50	6.50	10.20	82.00	18.50	48.00	12.000
M14	2.00	OH3	10.50	8.00	12.00	88.00	20.00	48.00	14.000
M16	2.00	OH3	12.50	10.00	14.00	95.00	20.00	52.00	16.000
M18	2.50	OH4	14.00	11.00	15.50	100.00	25.00	55.00	18.000
M20	2.50	OH4	15.00	12.00	17.50	105.00	25.00	58.00	20.000

JIS taps for ISO metric threads

Article no. 80880



P	M	K	N	S	H
•	•	○	○	○	

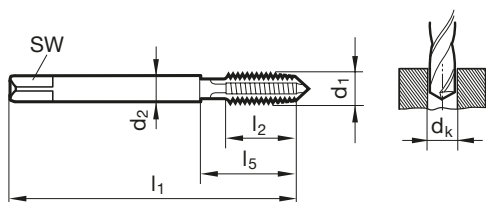

d1	P	Tolerance	d2	SW	dk	l1	l2	l3	Code no.
mm	mm		mm	mm	mm	mm	mm	mm	
M2	0.40	OH2	3.00	2.50	1.60	40.00	8.00	15.00	2.000
M2,5	0.45	OH2	3.00	2.50	2.05	44.00	9.00	16.00	2.500
M3	0.50	OH2	4.00	3.20	2.50	46.00	10.00	19.00	3.000
M4	0.70	OH2	5.00	4.00	3.30	52.00	12.00	20.00	4.000
M5	0.80	OH2	5.50	4.50	4.20	60.00	14.00	24.00	5.000
M6	1.00	OH2	6.00	4.50	5.00	62.00	16.00	29.00	6.000
M7	1.00	OH2	6.20	5.00	6.00	65.00	16.00	33.00	7.000
M8	1.25	OH2	6.20	5.00	6.80	70.00	17.00	37.00	8.000
M9	1.25	OH2	7.00	5.50	7.80	72.00	17.00	39.00	9.000
M10	1.50	OH2	7.00	5.50	8.50	75.00	20.00	41.00	10.000
M12	1.75	OH3	8.50	6.50	10.20	82.00	24.00	48.00	12.000
M14	2.00	OH3	10.50	8.00	12.00	88.00	26.00	48.00	14.000
M16	2.00	OH3	12.50	10.00	14.00	95.00	26.00	52.00	16.000
M18	2.50	OH4	14.00	11.00	15.50	100.00	30.00	55.00	18.000
M20	2.50	OH4	15.00	12.00	17.50	105.00	32.00	58.00	20.000

JIS taps for ISO metric threads

Article no. 80890



P	M	K	N	S	H
•	•	○	○	○	

HSS-E

TG 100 T
OH2
JISB 4430

Cyl
C

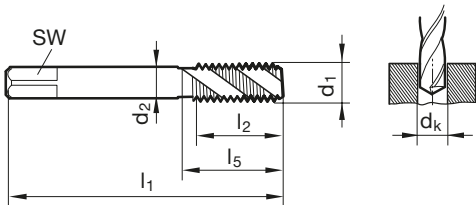

d1	P	Tolerance	d2	SW	dk	l1	l2	l3	Code no.
mm	mm		mm	mm	mm	mm	mm	mm	
M2	0.40	OH2	3.00	2.50	1.60	40.00	4.50	15.00	2.000
M2,3	0.40	OH2	3.00	2.50	1.90	42.00	4.50	15.00	2.300
M2,5	0.45	OH2	3.00	2.50	2.05	44.00	5.00	16.00	2.500
M2,6	0.45	OH2	3.00	2.50	2.15	44.00	5.00	16.00	2.600
M3	0.50	OH2	4.00	3.20	2.50	46.00	6.00	19.00	3.000
M3,5	0.60	OH2	4.00	3.20	2.90	48.00	7.00	20.00	3.500
M4	0.70	OH2	5.00	4.00	3.30	52.00	7.50	20.00	4.000
M5	0.80	OH2	5.50	4.50	4.20	60.00	8.50	24.00	5.000
M6	1.00	OH2	6.00	4.50	5.00	62.00	11.00	29.00	6.000
M7	1.00	OH2	6.20	5.00	6.00	65.00	11.00	33.00	7.000
M8	1.25	OH2	6.20	5.00	6.80	70.00	14.00	37.00	8.000
M9	1.25	OH2	7.00	5.50	7.80	72.00	14.00	39.00	9.000
M10	1.50	OH2	7.00	5.50	8.50	75.00	16.00	41.00	10.000
M12	1.75	OH3	8.50	6.50	10.20	82.00	18.50	48.00	12.000
M14	2.00	OH3	10.50	8.00	12.00	88.00	20.00	48.00	14.000
M16	2.00	OH3	12.50	10.00	14.00	95.00	20.00	52.00	16.000
M18	2.50	OH4	14.00	11.00	15.50	100.00	25.00	55.00	18.000
M20	2.50	OH4	15.00	12.00	17.50	105.00	25.00	58.00	20.000
M22	2.50	OH4	17.00	13.00	19.50	115.00	27.00	63.00	22.000
M24	3.00	OH4	19.00	15.00	21.00	120.00	30.00	66.00	24.000
M30	3.50	OH4	23.00	17.00	26.50	135.00	30.00	74.00	30.000

JIS taps for ISO metric fine threads

Article no. 80781



P	M	K	N	S	H
•	○	○			

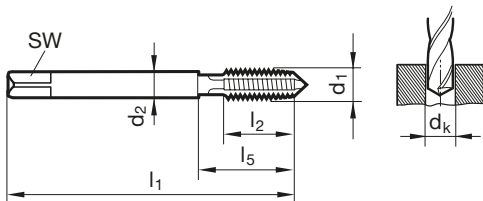

d1	Tolerance	d2 mm	SW mm	dk mm	l1 mm	l2 mm	l3 mm	Code no.
M6 x 0,75	OH2	6.00	4.50	5.20	62.00	13.00	30.00	6.004
M8 x 1	OH2	6.20	5.00	7.00	70.00	17.00	35.00	8.005
M10 x 1	OH2	7.00	5.50	9.00	70.00	16.00	35.00	10.005
M10 x 1,25	OH2	7.00	5.50	8.80	75.00	20.00	39.00	10.006
M12 x 1	OH2	8.50	6.50	11.00	70.00	20.00	40.00	12.005
M12 x 1,25	OH2	8.50	6.50	10.80	80.00	20.00	40.00	12.006
M12 x 1,5	OH2	8.50	6.50	10.50	82.00	20.00	40.00	12.007
M14 x 1,5	OH2	10.50	8.00	12.50	88.00	20.00	40.00	14.007
M16 x 1,5	OH2	12.50	10.00	14.50	95.00	22.00	44.00	16.007
M20 x 1,5	OH2	15.00	12.00	18.50	95.00	25.00	44.00	20.007

JIS taps for ISO metric fine threads

Article no. 80791



P	M	K	N	S	H
•	○	○			

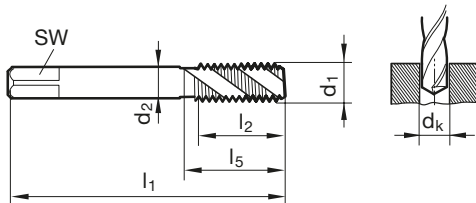

d1	Tolerance	d2 mm	SW mm	dk mm	l1 mm	l2 mm	l3 mm	Code no.
M6 x 0,75	OH2	6.00	4.50	5.20	62.00	8.00	30.00	6.004
M8 x 1	OH2	6.20	5.00	7.00	70.00	11.00	35.00	8.005
M10 x 1	OH2	7.00	5.50	9.00	70.00	11.00	35.00	10.005
M10 x 1,25	OH2	7.00	5.50	8.80	75.00	14.00	39.00	10.006
M12 x 1	OH2	8.50	6.50	11.00	70.00	11.00	40.00	12.005
M12 x 1,25	OH2	8.50	6.50	10.80	80.00	15.00	40.00	12.006
M12 x 1,5	OH2	8.50	6.50	10.50	82.00	15.00	40.00	12.007
M14 x 1,5	OH2	10.50	8.00	12.50	88.00	15.00	40.00	14.007
M16 x 1,5	OH2	12.50	10.00	14.50	95.00	15.00	44.00	16.007
M20 x 1,5	OH2	15.00	12.00	18.50	95.00	16.00	44.00	20.007

JIS taps for ISO metric fine threads

Article no. 80881



P	M	K	N	S	H
•	•	○	○	○	

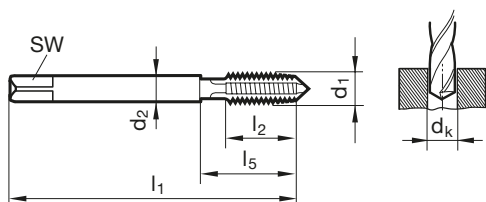

d1	Tolerance	d2 mm	SW mm	dk mm	l1 mm	l2 mm	l3 mm	Code no.
M6 x 0,75	OH2	6.00	4.50	5.20	62.00	13.00	30.00	6.004
M8 x 1	OH2	6.20	5.00	7.00	70.00	17.00	35.00	8.005
M10 x 1	OH2	7.00	5.50	9.00	70.00	16.00	35.00	10.005
M10 x 1,25	OH2	7.00	5.50	8.80	75.00	20.00	39.00	10.006
M12 x 1	OH2	8.50	6.50	11.00	70.00	20.00	40.00	12.005
M12 x 1,25	OH2	8.50	6.50	10.80	80.00	20.00	40.00	12.006
M12 x 1,5	OH2	8.50	6.50	10.50	82.00	20.00	40.00	12.007
M14 x 1,5	OH2	10.50	8.00	12.50	88.00	20.00	40.00	14.007
M16 x 1,5	OH2	12.50	10.00	14.50	95.00	22.00	44.00	16.007
M18 x 1,5	OH2	14.00	11.00	16.50	95.00	25.00	44.00	18.007
M20 x 1,5	OH2	15.00	12.00	18.50	95.00	25.00	44.00	20.007

JIS taps for ISO metric fine threads

Article no. 80891



P	M	K	N	S	H
•	•	○	○	○	

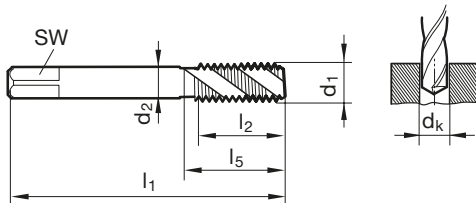

d1	Tolerance	d2 mm	SW mm	dk mm	l1 mm	l2 mm	l3 mm	Code no.
M4 x 0,5	OH2	5.00	4.00	3.50	52.00	5.00	21.00	4.003
M5 x 0,5	OH2	5.50	4.50	4.50	52.00	5.00	25.00	5.003
M6 x 0,5	OH2	6.00	4.50	5.50	52.00	5.00	30.00	6.003
M6 x 0,75	OH2	6.00	4.50	5.20	62.00	8.00	30.00	6.004
M8 x 0,75	OH2	6.20	5.00	7.20	62.00	8.00	30.00	8.004
M8 x 1	OH2	6.20	5.00	7.00	70.00	11.00	35.00	8.005
M10 x 1	OH2	7.00	5.50	9.00	70.00	11.00	35.00	10.005
M10 x 1,25	OH2	7.00	5.50	8.80	75.00	14.00	39.00	10.006
M12 x 1	OH2	8.50	6.50	11.00	70.00	11.00	40.00	12.005
M12 x 1,25	OH2	8.50	6.50	10.80	80.00	15.00	40.00	12.006
M12 x 1,5	OH2	8.50	6.50	10.50	82.00	15.00	40.00	12.007
M14 x 1,5	OH2	10.50	8.00	12.50	88.00	15.00	40.00	14.007
M16 x 1,5	OH2	12.50	10.00	14.50	95.00	15.00	44.00	16.007
M18 x 1,5	OH2	14.00	11.00	16.50	95.00	16.00	44.00	18.007
M20 x 1,5	OH2	15.00	12.00	18.50	95.00	16.00	44.00	20.007
M22 x 1,5	OH2	17.00	13.00	20.50	95.00	16.00	44.00	22.007



JIS fluteless taps for ISO metric threads

Article no. 80980



P	M	K	N	S	H
•	•	○	○		

HSS-E
T
N
Class2/RH
JISB 4430
R
Cyl
C

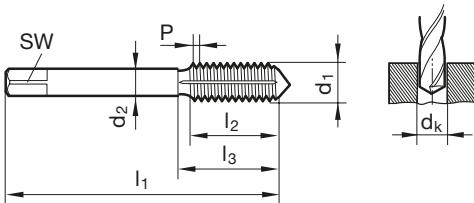

d1	P	Tolerance	d2	SW	dk	l1	l2	l3	Code no.
mm	mm		mm	mm	mm	mm	mm	mm	
M4	0.70	RH6	5.00	4.00	3.70	52.00	12.00	20.00	4.000
M5	0.80	RH6	5.50	4.50	4.65	60.00	14.00	24.00	5.000
M6	1.00	RH7	6.00	4.50	5.55	62.00	16.00	29.00	6.000
M8	1.25	RH7	6.20	5.00	7.40	70.00	17.00	37.00	8.000
M10	1.50	RH7	7.00	5.50	9.30	75.00	20.00	41.00	10.000
M12	1.75	RH8	8.50	6.50	11.20	82.00	24.00	48.00	12.000
M16	2.00	RH10	12.50	10.00	15.10	95.00	26.00	52.00	16.000
M20	2.50	RH11	15.00	12.00	18.90	105.00	32.00	58.00	20.000



JIS fluteless taps for ISO metric fine threads

Article no. 80981



P	M	K	N	S	H
•	•	○	○		

HSS-E
T
N
Class2/
RH
JISB
4430
R
Cyl
C

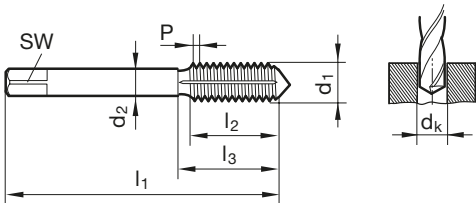

d1	Tolerance	d2 mm	SW mm	dk mm	l1 mm	l2 mm	l3 mm	Code no.
M6 x 0,75	RH6	6.00	4.50	5.65	62.00	13.00	30.00	6.004
M8 x 1	RH7	6.20	5.00	7.55	70.00	17.00	35.00	8.005
M10 x 1	RH7	7.00	5.50	9.55	70.00	16.00	35.00	10.005
M10 x 1,25	RH7	7.00	5.50	9.40	75.00	20.00	39.00	10.006
M12 x 1	RH7	8.50	6.50	11.55	70.00	20.00	40.00	12.005
M12 x 1,25	RH7	8.50	6.50	11.40	80.00	20.00	40.00	12.006
M12 x 1,5	RH7	8.50	6.50	11.30	82.00	20.00	40.00	12.007
M14 x 1,5	RH9	10.50	8.00	13.30	88.00	20.00	40.00	14.007
M16 x 1,5	RH9	12.50	10.00	15.30	95.00	22.00	44.00	16.007
M20 x 1,5	RH10	15.00	12.00	19.30	95.00	25.00	44.00	20.007



Taps for manual machining

Article no. 80990



P	M	K	N	S	H
≤ 1000	○	●	●		

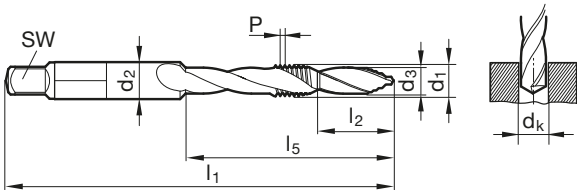

d1	P	d2	SW	dk	l1	l5	l5	Code no.
	mm	mm	mm	mm	mm	mm	mm	
M4	0.70	5.00	3.80	3.30	66.00	10.000	28.00	4.000
M5	0.80	6.00	4.90	4.20	75.00	12.000	34.00	5.000
M6	1.00	8.00	6.20	5.00	91.00	14.000	40.00	6.000
M8	1.25	10.00	8.00	6.80	103.00	18.000	52.00	8.000
M10	1.50	12.00	9.00	8.50	125.00	24.000	65.00	10.000
M12	1.75	12.00	9.00	10.20	135.00	28.000	77.00	12.000



Taps for manual machining

Article no. 80991



P	M	K	N	S	H
•	•				

HSS-E
○
N
6HX
DIN 371
R
Cyl
C
↓
⊗

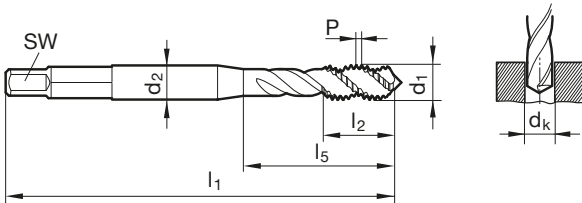

d1	P	d2	SW	dk	l1	l2	l5	Code no.
mm	mm	mm	mm	mm	mm	mm	mm	
M4	0.70	4.50	3.40	3.30	63.00	7.50	21.00	4.000
M5	0.80	6.00	4.90	4.20	70.00	8.50	25.00	5.000
M6	1.00	6.00	4.90	5.00	80.00	11.00	30.00	6.000
M8	1.25	8.00	6.20	6.80	90.00	14.00	35.00	8.000
M10	1.50	10.00	8.00	8.50	100.00	16.00	39.00	10.000
M12	1.75	9.00	7.00	10.20	110.00	18.50	49.00	12.000



Taps for manual machining

Article no. 80992



P	M	K	N	S	H
•	•				

HSS-E
VA
6HX
DIN 371
R
Cyl
B

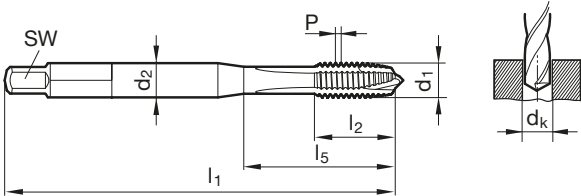

d1	P	d2	SW	dk	l1	l2	l5	Code no.
	mm	mm	mm	mm	mm	mm	mm	
M4	0.70	4.50	3.40	3.30	63.00	12.00	21.00	4.000
M5	0.80	6.00	4.90	4.20	70.00	14.00	25.00	5.000
M6	1.00	6.00	4.90	5.00	80.00	16.00	30.00	6.000
M8	1.25	8.00	6.20	6.80	90.00	17.00	35.00	8.000
M10	1.50	10.00	8.00	8.50	100.00	20.00	39.00	10.000
M12	1.75	9.00	7.00	10.20	110.00	24.00	49.00	12.000

TECHNICAL SECTION





DIN characteristic features

Overview applicable standards for DIN 2184

DIN 2184 stipulates the major dimensions for taps and fluteless taps required for the thread production with nominal diameter $d_1 > 0.9 \dots 113\text{mm}$. Part 1 is the general plan of dimensions for a long tool version, part 2 the general plan of dimensions for the short tool version. In accordance with the nominal diameter range

and dependent on the thread pitch, the number of teeth and the ratio total length, the general plan of dimensions includes the max. thread length, the shank designs (reinforced or reduced shank). A detailed illustration of shank forms and characteristic features can be found on the following pages.

Taps						
DIN 2184-1			DIN 2184-2			
Machine taps, long			Hand taps and short machine taps			
ISO metric standard threads		ISO metric fine threads	ISO metric standard threads		ISO metric fine threads	
DIN 371 DIN 376		DIN 371 DIN 374	DIN 352		DIN 2181	
UNC/BSW* thread	UNF thread	G thread	UNC/BSW thread	UNF thread	G thread	Pg thread
~DIN 371 ~DIN 376	~DIN 371 ~DIN 374	DIN 5156	~DIN 352	~DIN 2181	DIN 5157	DIN 40 432

Fluteless taps				
DIN 2184-1				
DIN 2174		DIN 2184-1		
ISO metric standard threads	ISO metric fine thread	UNC thread	UNF thread	G thread
previously DIN 371 DIN 376	previously DIN 371 DIN 374	previously ~DIN 371 ~DIN 376	previously ~DIN 371 ~DIN 374	previously DIN 5156

Shank forms threading tools



reinforced shank without neck



reinforced shank with neck



← Symbol used in table

reduced shank

Thread type	DIN		contained in the general plan	Nominal diameter ranges mm			
	Taps	Fluteless taps		0.9 ... 2.6	> 2.6 ... 6.35	> 6.35 ... 10.0	> 10.0
M/MJ ISO metric standard threads	DIN 371		2184-1	●	●	●	-
	DIN 376		2184-1	●	●	●	●
	DIN 352		2184-2	●	●	●	●
	DIN 2174		2184-1	●	●	●	●
MF/MJF ISO metric fine threads	DIN 371		2184-1	●	●	●	-
	DIN 374		2184-1	-	●	●	●
	DIN 2181		2184-2	●	●	●	●
	DIN 2174		2184-1	●	●	●	●
UNC/UNJC/BSW threads	~DIN 371		2184-1	●	●	●	-
	~DIN 374		2184-1	●	●	●	●
	~DIN 352		2184-2	●	●	●	●
UNF/UNJF threads	~DIN 371		2184-1	●	●	●	-
	~DIN 374		2184-1	-	●	●	●
	~DIN 2181		2184-2	●	●	●	●
G threads	DIN 5156		2184-1	-	●	●	●
	DIN 5157		2184-2	-	●	●	●
Pg threads	DIN 40 432		2184-2	-	-	-	●



DIN characteristic features

DIN 2184-1 General plan of dimensions

Nominal Ø mm	Shank designs mm			Pitch mm	Total length mm	max. thread length mm
	reinforced shank		reduced shank			
from...to	Ø	Effective length	Ø			
0.9...1.20	2.5	5.5	-	≤0.20	40	5.5
1.20...1.40	2.5	7.0	-	≤0.35	40	7.0
1.40...1.80	2.5	8.0	-	≤0.35	40	8.0
1.80...2.00	2.8	8.0	-	≤0.40	45	8.0
2.00...2.30	2.8	9.0	-	≤0.40	45	9.0
2.30...2.60	2.8	9.0	-	≤0.50	50	9.0
2.60...3.20	3.5	18	2.2	≤0.45	56	8.0
2.60...3.20	3.5	18	2.2	0.50...0.60	56	11.0
3.20...3.55	4.0	20	2.5	≤0.50	56	9.0
3.20...3.55	4.0	20	2.5	0.60...0.80	56	12.0
3.55...4.20	4.5	21	2.8	≤0.50	63	10.0
3.55...4.20	4.5	21	2.8	0.60...0.80	63	13.0
4.20...4.55	6.0	25	3.5	≤0.60	70	12.0
4.20...4.55	6.0	25	3.5	0.70...0.80	70	16.0
4.55...5.00	6.0	25	3.5	≤0.75	70	12.0
4.55...5.00	6.0	25	3.5	0.80...1.00	70	16.0
5.00...5.60	6.0	30	4.0	≤0.75	80	12.0
5.00...5.60	6.0	30	4.0	0.80...1.00	80	17.0
5.60...6.10	6.0	30	4.5	≤0.80	80	14.0
5.60...6.10	6.0	30	4.5	1.0	80	19.0
6.10...6.40	7.0	30	4.5	≤0.80	80	14.0
6.10...6.40	7.0	30	4.5	1.00...1.25	80	19.0
6.40...7.00	7.0	30	5.5	≤0.80	80	14.0
6.40...7.00	7.0	30	5.5	1.00...1.25	80	19.0
7.00...8.00	8.0	30	6.0	≤0.80	80	18.0
7.00...8.00	8.0	35	6.0	1.00...1.50	90	22.0
8.00...9.00	9.0	30	7.0	≤0.80	90	18.0
8.00...9.00	9.0	35	7.0	1.00...1.50	90	22.0
9.00...10.15	10.0	35	7.0	≤1.00	90	20.0
9.00...10.15	10.0	39	7.0	1.25...1.50	100	24.0
10.15...11.15	-	-	8.0	0.25...1.00	90	20.0
10.15...11.15	-	-	8.0	1.25...1.75	100	24.0
11.15...12.80	-	-	9.0	0.25...1.50	100	22.0
11.15...12.80	-	-	9.0	1.75...2.00	110	28.0
12.80...14.35	-	-	11.0	0.25...1.50	100	22.0
12.80...14.35	-	-	11.0	1.75...2.00	110	30.0
14.35...17.10	-	-	12.0	0.25...1.50	100	22.0
14.35...17.10	-	-	12.0	1.75...2.00	110	32.0
17.10...19.10	-	-	14.0	0.25...1.50	110	25.0
17.10...19.10	-	-	14.0	1.75...2.50	125	34.0
19.10...21.15	-	-	16.0	0.25...1.75	125	25.0
19.10...21.15	-	-	16.0	2.00...2.50	140	34.0
21.15...23.00	-	-	18.0	0.25...1.75	125	25.0
21.15...23.00	-	-	18.0	2.00...2.50	140	34.0
23.00...26.00	-	-	18.0	0.25...2.00	140	28.0
23.00...26.00	-	-	18.0	2.50...3.00	160	38.0
26.00...28.15	-	-	20.0	0.25...2.00	140	28.0
26.00...28.15	-	-	20.0	2.50...3.00	160	38.0
28.15...30.20	-	-	22.0	0.25...2.00	150	28.0
28.15...30.20	-	-	22.0	2.50...3.50	180	45.0
30.20...32.00	-	-	22.0	0.25...2.00	150	28.0
30.20...32.00	-	-	22.0	2.50...3.50	180	50.0
32.00...33.30	-	-	25.0	0.25...2.00	160	30.0
32.00...33.30	-	-	25.0	2.50...3.50	180	50.0
33.30...38.20	-	-	28.0	0.25...2.00	170	30.0
33.30...38.20	-	-	28.0	2.50...4.50	200	56.0
38.20...42.00	-	-	32.0	0.25...2.00	170	30.0
38.20...42.00	-	-	32.0	2.50...4.50	200	60.0
42.00...45.00	-	-	36.0	0.25...2.00	180	32.0
42.00...45.00	-	-	36.0	2.50...3.00	200	50.0
42.00...45.00	-	-	36.0	3.50...5.00	220	69.0
45.00...50.00	-	-	36.0	0.25...2.00	190	82.0
45.00...50.00	-	-	36.0	2.50...3.00	225	50.0
45.00...50.00	-	-	36.0	3.50...5.00	250	70.0



DIN characteristic features

DIN 371 in the general plan DIN 2184-1

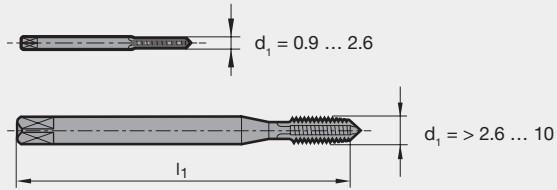

Standard for machine taps with reinforced shank for standard ISO metric threads and ISO metric fine threads. Long version. Shank design in accordance with diameter ranges shown opposite (mm).

DIN 376 in the general plan DIN 2184-1

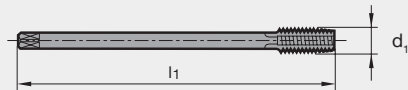

Standard for machine taps with reduced shank (machine nut tap) for standard ISO metric threads. Long version. Diameter range $d_1 = 1.6 \dots 68$ mm ($\leq \text{Ø M3}$, shank without square)

DIN 374 in the general plan DIN 2184-1

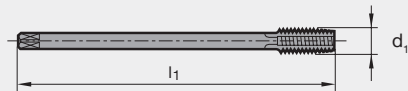

Standard for machine taps with reduced shank (machine nut tap) for ISO metric fine threads. Long version. Diameter range $d_1 = 3 \dots 52$ mm

DIN 352 in the general plan DIN 2184-2

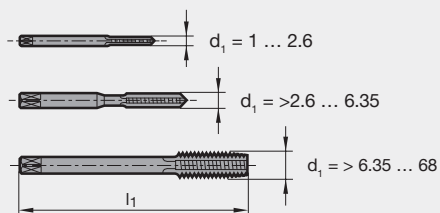

Standard for hand and machine taps for standard ISO metric threads. Short version. Shank design in accordance with diameter ranges shown opposite (mm).



DIN characteristic features

DIN 2181 in the general plan DIN 2184-2

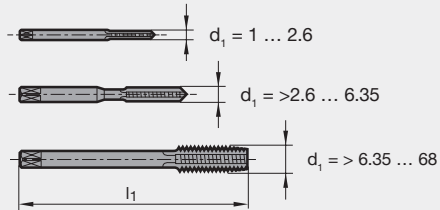

Standard for hand and machine taps for standard ISO metric threads. Short version. Shank design in accordance with diameter ranges shown opposite (mm).

DIN 5156 in the general plan DIN 2184-1

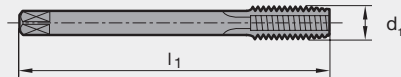

Standard for machine taps for pipe thread to DIN EN ISO 228 and for taps for pipe thread to DIN EN 10226. Long version.

Diameter ranges for taps
to DIN EN ISO 228 from G 1/16" to G4"
to DIN EN 10226 from Rp 1/16" to Rp 4"

DIN 5157 in the general plan DIN 2184-2

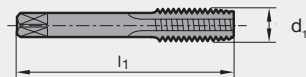

Standard for machine taps for BSPP threads to DIN ISO 228 and for BSP threads to DIN EN 10 226-1. Short version.

Diameter ranges:
BSPP threads G 1/16" ... G 4"
BSP threads Rp 1/16" ... Rp 4"

DIN 40 432 in the general plan DIN 2184-2

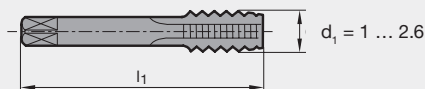

Standard for machine taps for steel armoured conduit threads to DIN 40 430. Short version.

Diameter range:
Pg 7 (12.5 mm) ... Pg 48 (59.3 mm)
Will be replaced by DIN 374 ISO 3 6G.



DIN characteristic features

DIN 2174

in the general plan DIN 2184-1

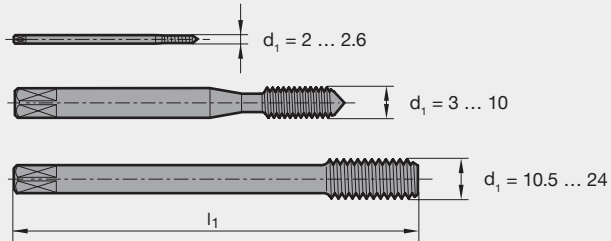

Standard for fluteless taps for standard ISO metric threads and ISO metric fine threads. Long version. Shank design in accordance with diameter ranges shown opposite (mm).

DIN 40 435

in the general plan DIN 2184-1

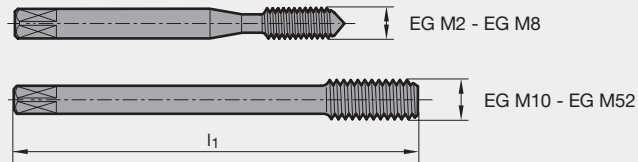

Standard for machine taps for tapped holes (EG) for wire thread inserts as in DIN 8140 for ISO metric threads. Standard thread tapped holes EG M2 to EG M52 and fine thread tapped holes EG M8 x1 to EG M48 x 3



Comparison of standards

DIN 2184-1
DIN 2184-2

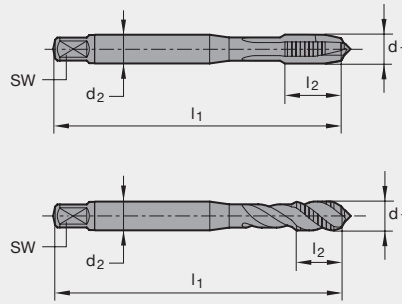

JIS B 4430
Japan Industrial Standard

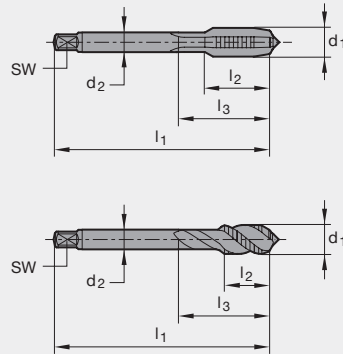

ISO 529

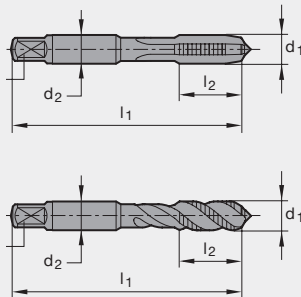

ASME B94.9
The American Society
of Mechanical Engineers

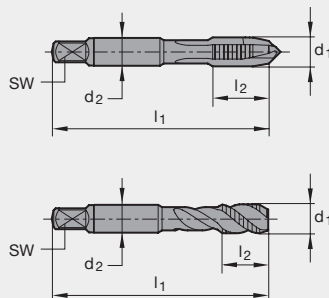

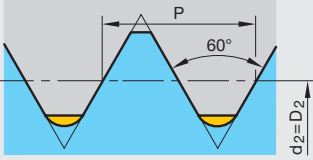
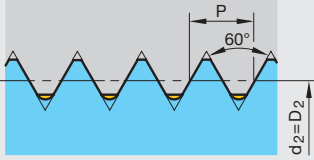
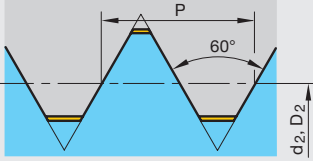
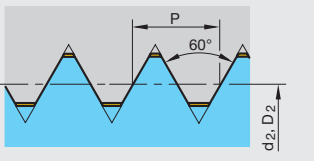
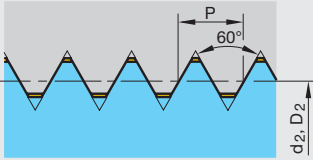
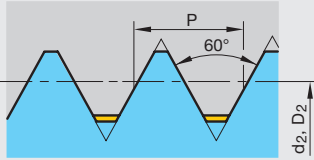
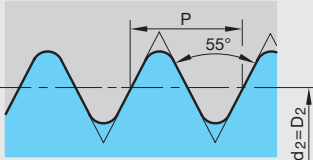
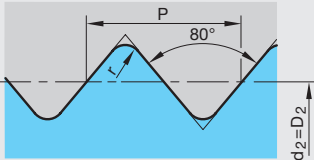
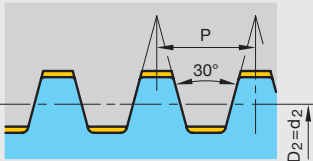
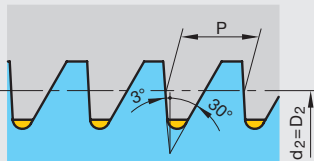
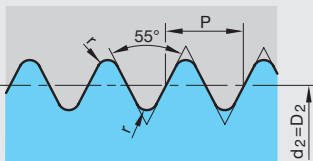
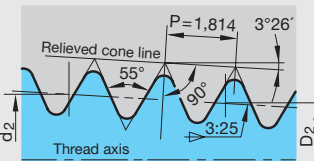
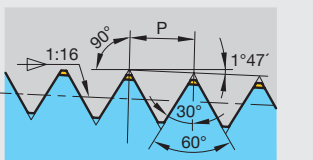
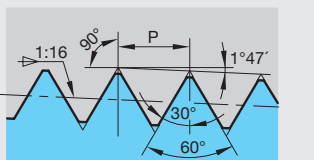

The characteristics of different thread types

Geometry drawing	Standard	Application	Geometry drawing	Standard	Application
M ISO metric thread			MF ISO metric fine thread		
	DIN 13-1	General standard thread		DIN 13-2 to DIN 13-11	General fine thread
UNC Unified National Coarse thread			UNF Unified National Fine thread		
	ASME B1.1	General UN standard thread		ASME B1.1 ISO metric trapezoidal thread	General UN fine thread
UNEF Unified National Extra Fine thread			UNS Unified Special thread		
	ASME B1.1	General UN extra fine thread		ASME B1.1	General UN special thread
G Cylindrical Pipe thread without thread sealing connections			PG steel conduit thread		
	DIN EN ISO 228-1	Threads for pipes, pipe connections and fittings		DIN 40430 cylindrical round thread	Electrical engineering
TR ISO metric trapezoidal thread			S metric saw thread		
	DIN 103	General, draw collets, rolling stock		DIN 513	When absorbing uni-directional forces
W Cylindrical Whitworth thread			W Whitworth taper thread		
	DIN 477	Side connector and accessories for gas bottle valves		DIN 477	Threaded connection in gas cylinder bottles for valves
NPT American Standard Pipe thread tapered for sealing			NPTF American Standard Pipe thread tapered for dry sealing		
	ANSI/ASME B1.20.1	Pipe threads and fittings		ANSI B1.20.3	Pipe threads and fittings



The characteristics of different thread types

Geometry drawing	Standard	Application	Geometry drawing	Standard	Application
BSW cylindrical Whitworth thread					
	B.S. 84 British Standard	Threads for pipes, pipe connections and fittings		B.S. 84 British Standard Fine	Threads for pipes, pipe connections and fittings
BSP pipe thread cylindrical (identical to G)					
	B.S. 93 British Standard	Threads for pipes, pipe connections and fittings	BSPT pipe thread tapered (identical to Rc)		
	DIN EN 10226-1 (based on ISO 7-1) replacement for DIN 2999-1	External thread for pipe threads and fittings (for in the thread sealing connections)		B.S. 93 British Standard	Internal thread for pipe threads and fittings
Rc Whitworth pipe thread tapered internal thread					
	DIN ISO 10226-2 (hardly used in Europe, replaceable with pipe threads to ISO 7-1)	Internal thread for pipe threads and fittings (for in the thread sealing connections)	RD cylindrical round thread		
	DIN ISO 5855-1	For the aerospace industry		DIN EN 10226-1 (based on ISO 7-1) Replacement for DIN 2999-1	Internal thread for pipe threads and fittings (for in the thread sealing connections)
Vg valve thread					
	DIN 7756	Valves for car tyres manifold block	MSG lock nut thread		
	DIN 8141	Interference fits in aluminium cast alloys		DIN 405	General, load hook, mining, food industry
<div style="display: flex; justify-content: space-around; align-items: center;"> <div style="width: 20px; height: 10px; background-color: #00AEEF; border: 1px solid black;"></div> External thread </div> <div style="display: flex; justify-content: space-around; align-items: center;"> <div style="width: 20px; height: 10px; background-color: #A9A9A9; border: 1px solid black;"></div> Internal thread </div> <div style="display: flex; justify-content: space-around; align-items: center;"> <div style="width: 20px; height: 10px; background-color: #FFD700; border: 1px solid black;"></div> Play </div>					



Tapping size holes for thread cutting

Standard ISO metric threads DIN 13					ISO metric fine threads DIN 13									UNC threads ASME B1.1				
Nom. Ø	Pitch P	Tapping size hole Ø		Core diameter of int. thread 6H*	Nom. Ø	Pitch P	Tapping size hole Ø			Nom. Ø	Pitch P	Tapping size hole Ø		Nom. Ø	Thread	Tapping size hole Ø		
		DIN 336	min. mm				max. mm	DIN 336	min. mm			max. mm	DIN 336			min. mm	max. mm	per inch
M 1	0.25	0.75	0.729	0.785	M 2.5 x 0.35		2.15	2.121	2.221	M 22 x 1.00		21.00	20.917	21.153	No. 1 - 64	1.55	1.425	1.580
M 1.1	0.25	0.85	0.829	0.885	M 3.0 x 0.35		2.65	2.621	2.721	M 22 x 1.50		20.50	20.376	20.676	No. 2 - 56	1.85	1.694	1.872
M 1.2	0.25	0.95	0.929	0.985	M 3.5 x 0.35		3.15	3.121	3.221	M 22 x 2.00		20.00	19.835	20.210	No. 3 - 48	2.10	1.941	2.146
M 1.4	0.30	1.10	1.075	1.142	M 4.0 x 0.50		3.50	3.459	3.599	M 24 x 1.00		23.00	22.917	23.153	No. 4 - 40	2.35	2.157	2.385
M 1.6	0.35	1.25	1.221	1.321	M 4.5 x 0.50		4.00	3.959	4.099	M 24 x 1.50		22.50	22.376	22.676	No. 5 - 40	2.65	2.487	2.698
M 1.8	0.35	1.45	1.421	1.521	M 5.0 x 0.50		4.50	4.459	4.599	M 24 x 2.00		22.00	21.835	22.210	No. 6 - 32	2.85	2.642	2.896
M 2	0.40	1.60	1.567	1.679	M 5.5 x 0.50		5.00	4.959	5.099	M 25 x 1.00		24.00	23.917	24.153	No. 8 - 32	3.50	3.302	3.531
M 2.2	0.45	1.75	1.713	1.838	M 6.0 x 0.75		5.20	5.188	5.378	M 25 x 1.50		23.50	23.376	23.676	No. 10 - 24	3.90	3.683	3.937
M 2.5	0.45	2.05	2.013	2.138	M 7.0 x 0.75		6.20	6.188	6.378	M 25 x 2.00		23.00	22.835	23.210	No. 12 - 24	4.50	4.343	4.597
M 3	0.50	2.50	2.459	2.599	M 8.0 x 0.50		7.50	7.459	7.599	M 27 x 1.00		26.00	25.917	26.153	1/4 - 20	5.10	4.978	5.258
M 3.5	0.60	2.90	2.850	3.010	M 8.0 x 0.75		7.20	7.188	7.378	M 27 x 1.50		25.50	25.376	25.676	5/16 - 18	6.60	6.401	6.731
M 4	0.70	3.30	3.242	3.422	M 8.0 x 1.00		7.00	6.917	7.153	M 27 x 2.00		25.00	24.835	25.210	3/8 - 16	8.00	7.798	8.153
M 4.5	0.75	3.70	3.688	3.878	M 9.0 x 0.75		8.20	8.188	8.378	M 28 x 1.00		27.00	26.917	27.153	7/16 - 14	9.40	9.144	9.550
M 5	0.80	4.20	4.134	4.334	M 9.0 x 1.00		8.00	7.917	8.153	M 28 x 1.50		26.50	26.376	26.676	1/2 - 13	10.80	10.592	11.024
M 6	1.00	5.00	4.917	5.153	M 10 x 0.75		9.20	9.188	9.378	M 28 x 2.00		26.00	25.835	26.210	9/16 - 12	12.20	11.989	12.446
M 7	1.00	6.00	5.917	6.153	M 10 x 1.00		9.00	8.917	9.153	M 30 x 1.00		29.00	28.917	29.153	5/8 - 11	13.50	13.386	13.868
M 8	1.25	6.80	6.647	6.912	M 10 x 1.25		8.80	8.647	8.912	M 30 x 1.50		28.50	28.376	28.676	3/4 - 10	16.50	16.307	16.840
M 9	1.25	7.80	7.647	7.912	M 11 x 0.75		10.20	10.188	10.378	M 30 x 2.00		28.00	27.835	28.210	7/8 - 9	19.50	19.177	19.761
M 10	1.50	8.50	8.376	8.676	M 11 x 1.00		10.00	9.917	10.153	M 30 x 3.00		27.00	26.752	27.252	1 - 8	22.25	21.971	22.606
M 11	1.50	9.50	9.376	9.676	M 12 x 1.00		11.00	10.917	11.153	M 32 x 1.50		30.50	30.376	30.676	1 1/8 - 7	25.00	24.638	25.349
M 12	1.75	10.20	10.106	10.441	M 12 x 1.25		10.80	10.647	10.912	M 32 x 2.00		30.00	29.835	30.210	1 1/4 - 7	28.00	27.813	28.524
M 14	2.00	12.00	11.835	12.210	M 12 x 1.50		10.50	10.376	10.676	M 33 x 1.50		31.50	31.376	31.676	1 3/8 - 6	30.75	30.353	31.115
M 16	2.00	14.00	13.835	14.210	M 14 x 1.00		13.00	12.917	13.153	M 33 x 2.00		31.00	30.835	31.210	1 1/2 - 6	34.00	33.528	34.290
M 18	2.50	15.50	15.294	15.744	M 14 x 1.25		12.80	12.647	12.912	M 33 x 3.00		30.00	29.752	30.252	1 3/4 - 5	39.50	38.938	39.802
M 20	2.50	17.50	17.294	17.744	M 14 x 1.50		12.50	12.376	12.676	M 35 x 1.50		33.50	33.376	33.676	2 - 4.5	45.00	44.679	45.593
M 22	2.50	19.50	19.294	19.744	M 15 x 1.00		14.00	13.917	14.153	M 36 x 1.50		34.50	34.376	34.676				
M 24	3.00	21.00	20.752	21.252	M 15 x 1.50		13.50	13.376	13.676									
M 27	3.00	24.00	23.752	24.252	M 16 x 1.00		15.00	14.917	15.153									
M 30	3.50	26.50	26.211	26.771	M 16 x 1.25		14.80	14.647	14.912									
M 33	3.50	29.50	29.211	29.771	M 16 x 1.50		14.50	14.376	14.676									
M 36	4.00	32.00	31.670	32.270	M 17 x 1.00		16.00	15.917	16.153									
M 39	4.00	35.00	34.670	35.270	M 17 x 1.50		15.50	15.376	15.676									
M 42	4.50	37.50	37.129	37.799	M 18 x 1.00		17.00	16.917	17.153									
M 45	4.50	40.50	40.129	40.799	M 18 x 1.50		16.50	16.376	16.676									
M 48	5.00	43.00	42.587	43.297	M 20 x 1.00		19.00	18.917	19.153									
M 52	5.00	47.00	46.587	47.297	M 20 x 1.50		18.50	18.376	18.676									
M 56	5.50	50.50	50.046	50.796	M 20 x 2.00		18.00	17.835	18.210									

* M 1.1 up to M 1.4 tapping size hole of internal thread 5H

MJ threads DIN ISO 5855					
Nom. Ø	x	Pitch P	Tapping size hole Ø		Core diameter of int. thread 5H*
			mm	mm	
MJ 3	x	0.50	2.60	2.513	2.653
MJ 4	x	0.70	3.40	3.318	3.498
MJ 5	x	0.80	4.30	4.221	4.421
MJ 6	x	0.50	5.55	5.513	5.625
MJ 6	x	0.75	5.35	5.269	5.419
MJ 6	x	1.00	5.10	5.026	5.216
MJ 8	x	0.50	7.55	7.513	7.625
MJ 8	x	0.75	7.35	7.269	7.419
MJ 8	x	1.00	7.10	7.026	7.216
MJ 8	x	1.25	6.90	6.782	6.994
MJ 10	x	1.00	9.10	9.026	9.216
MJ 10	x	1.25	8.90	8.782	8.994
MJ 10	x	1.50	8.60	8.539	8.775
MJ 12	x	1.75	10.40	10.295	10.560
MJ 16	x	2.00	14.20	14.051	14.351

UNJC threads ISO 3161				
Nom. Ø	Thread	Tapping size hole Ø	Core diameter of int. thread 3B	
			mm	mm
No. 6 - 32		2.85	2.733	2.939
No. 8 - 32		3.55	3.393	3.599
No. 10 - 24		4.00	3.795	4.064
No. 12 - 24		4.60	4.455	4.704
1/4 - 20		5.30	5.113	5.387
5/16 - 18		6.75	6.563	6.833
3/8 - 16		8.20	7.978	8.255
7/16 - 14		9.60	9.346	9.639
1/2 - 13		11.00	10.798	11.095
9/16 - 12		12.40	12.228	12.482
5/8 - 11		13.80	13.627	13.904

UNJF threads ISO 3161				
Nom. Ø	Thread	Tapping size hole Ø	Core diameter of int. thread 3B	
			mm	mm
No. 6 - 40		3.00	2.888	3.053
No. 8 - 36		3.60	3.480	3.663
No. 10 - 32		4.20	4.054	4.255
No. 12 - 28		4.75	4.602	4.816
1/4 - 28		5.60	5.466	5.662
5/16 - 24		7.00	6.906	7.109
3/8 - 24		8.60	8.494	8.679
7/16 - 20		10.00	9.876	10.084
1/2 - 20		11.60	11.463	11.661
9/16 - 18		13.00	12.913	13.122
5/8 - 18		14.60	14.501	14.702

* MJ3 x 0.50 up to MJ 5 x 0.80 tapping size hole of internal thread 6H



Tapping size holes for thread cutting

UNF threads ASME B1.1					BSW threads BS84					BSP threads (DIN-ISO 228-1)					Steel armoured conduit threads to DIN 40430				
Nom. Ø	Thread per inch	Tapping size hole Ø	Core diameter of int. thread 2B		Nom. Ø	Thread per inch	Tapping size hole Ø	Core diameter of int. thread		Nom. Ø	Thread per inch	Tapping size hole Ø	Core diameter of int. thread		Nom. Ø	Thread per inch	Tapping size hole Ø	Core diameter of int. thread	
			min. mm	max. mm				min. mm	max. mm				min. mm	max. mm				min. mm	max. mm
No. 1 - 72		1.55	1.473	1.610	W 1/16	60	1.20	1.045	1.230	G 1/16	28	6.80	6.561	6.843	Pg 7	20	11.40	11.280	11.430
No. 2 - 64		1.85	1.755	1.910	W 3/32	48	1.80	1.704	1.912	G 1/8	28	8.80	8.566	8.848	Pg 9	18	14.00	13.860	14.010
No. 3 - 56		2.15	2.024	2.197	W 1/8	40	2.50	2.362	2.591	G 1/4	19	11.80	11.445	11.890	Pg 11	18	17.30	17.260	17.410
No. 4 - 48		2.40	2.271	2.459	W 5/32	32	3.20	2.952	3.214	G 3/8	19	15.25	14.950	15.395	Pg 13.5	18	19.00	19.060	19.210
No. 5 - 44		2.70	2.550	2.741	W 3/16	24	3.60	3.407	3.745	G 1/2	14	19.00	18.631	19.172	Pg 16	18	21.30	21.160	21.310
No. 6 - 40		2.95	2.819	3.023	W 7/32	24	4.50	4.201	4.539	G 5/8	14	21.00	20.587	21.128	Pg 21	16	26.90	26.780	27.030
No. 8 - 36		3.50	3.404	3.607	W 1/4	20	5.10	4.724	5.156	G 3/4	14	24.50	24.117	24.658	Pg 29	16	35.50	35.480	35.730
No. 10 - 32		4.10	3.962	4.166	W 5/16	18	6.50	6.130	6.590	G 7/8	14	28.25	27.877	28.418	Pg 36	16	45.50	45.480	45.730
No. 12 - 28		4.60	4.496	4.724	W 3/8	16	7.90	7.492	7.987	G 1	11	30.75	30.291	30.931	Pg 42	16	52.50	52.480	52.730
1/4	- 28	5.50	5.359	5.588	W 7/16	14	9.20	8.789	9.330	G 1 1/8	11	35.50	34.939	35.579	Pg 48	16	57.80	57.780	58.030
5/16	- 24	6.90	6.782	7.036	W 1/2	12	10.50	9.989	10.591	G 1 1/4	11	39.50	38.952	39.592					
3/8	- 24	8.50	8.382	8.636	W 9/16	12	12.00	11.577	12.179	G 1 1/2	11	45.25	44.845	45.485					
7/16	- 20	9.90	9.728	10.033	W 5/8	11	13.50	12.918	13.558	G 1 3/4	11	51.00	50.788	51.428					
1/2	- 20	11.50	11.328	11.608	W 3/4	10	16.25	15.797	16.483	G 2	11	57.00	56.656	57.296					
9/16	- 18	12.90	12.751	13.081	W 7/8	9	19.25	18.611	19.353										
5/8	- 18	14.50	14.351	14.681	W 1	8	22.00	21.334	22.147										
3/4	- 16	17.50	17.323	17.678	W 1 1/8	7	24.50	23.928	24.832										
7/8	- 14	20.40	20.269	20.650	W 1 1/4	7	27.75	27.103	28.007										
1	- 12	23.25	23.114	23.571	W 1 3/8	6	30.50	29.504	30.528										
1 1/8	- 12	26.50	26.289	26.746	W 1 1/2	6	33.50	32.679	33.703										
1 1/4	- 12	29.50	29.464	29.921	W 1 5/8	5	35.50	34.769	35.963										
1 3/8	- 12	32.75	32.639	33.096	W 1 3/4	5	39.00	37.944	39.138										
1 1/2	- 12	36.00	35.814	36.271	W 2	4.5	44.50	43.571	44.877										

NPT ANSI B 2.1 American tapered pipe thread 1:16							
Version A (avoid if possible)	Version B	Nom. Ø	Thread per inch	Tapp. size hole Ø cylindrical (A) d1	Tapp. size hole Ø conical (B) D1	Cutting depth ET mm	Cutting depth BT (min) mm
		1/16	- 27	6.15	6.39	9.29	10.7
		1/8	- 27	8.40	8.74	9.32	10.8
		1/4	- 18	11.10	11.36	13.52	15.6
		3/8	- 18	14.30	14.80	13.83	16.0
		1/2	- 14	17.90	18.32	18.07	20.8
		3/4	- 14	23.30	23.67	18.55	21.3
		1	- 11,5	29.00	29.69	22.29	25.6
		1 1/4	- 11,5	37.70	38.45	22.80	26.1
		1 1/2	- 11,5	43.70	44.52	22.80	26.1
		2	- 11,5	55.60	56.56	23.20	26.5
		2 1/2	- 8	66.30	67.62	31.75	36.3
		3	- 8	82.30	83.52	33.74	38.5

Metric/metric fine EG-threads (EG M14 x 1.25) for wire thread inserts DIN 8140				
Nom. Ø	Pitch P	Tapping size hole Ø	Core diameter of int. thread	
			min. mm	max. mm
EG M 4 x 0.70		4.20	4.152	4.292
EG M 5 x 0.80		5.25	5.174	5.334
EG M 6 x 1.00		6.30	6.217	6.407
EG M 8 x 1.25		8.40	8.271	8.483
EG M10 x 1.50		10.50	10.324	10.560
EG M12 x 1.75		12.50	12.379	12.644
EG M14 x 1.25		14.40	14.271	14.483
EG M16 x 2.00		16.50	16.433	16.733

UNC (UNC-STI) EG-threads for wire thread inserts ASME B18.29.1				
Nom. Ø	Thread per inch	Tapping size hole Ø	Core diameter of int. thread	
			min. mm	max. mm
EG No. 6 - 32		3.80	3.678	3.879
EG No. 8 - 32		4.40	4.338	4.524
EG No. 10 - 24		5.20	5.055	5.283
EG No. 12 - 24		5.80	5.715	5.944
EG 1/4 - 20		6.70	6.624	6.868
EG 5/16 - 18		8.40	8.242	8.489
EG 3/8 - 16		10.00	9.868	10.127
EG 7/16 - 14		11.60	11.506	11.783
EG 1/2 - 13		13.30	13.122	13.393
EG 9/16 - 12		14.90	14.747	15.032
EG 5/8 - 11		16.50	16.375	16.673

UNF (UNF-STI) EG-threads for wire thread inserts ASME B18.29.1				
Nom. Ø	Thread per inch	Tapping size hole Ø	Core diameter of int. thread	
			min. mm	max. mm
EG No. 6 - 40		3.70	3.644	3.818
EG No. 8 - 36		4.40	4.321	4.498
EG No. 10 - 32		5.10	4.999	5.184
EG No. 12 - 28		5.70	5.682	5.809
EG 1/4 - 28		6.60	6.546	6.721
EG 5/16 - 24		8.25	8.166	8.352
EG 3/8 - 24		9.80	9.754	9.931
EG 7/16 - 20		11.50	11.389	11.585
EG 1/2 - 20		13.10	12.974	13.172
EG 9/16 - 18		14.70	14.592	14.798
EG 5/8 - 18		16.25	16.180	16.386



Recommended tapping size holes for thread forming

Standard ISO metric threads DIN 13						ISO metric fine threads DIN 13												
Nom. Ø	Pitch P	Tapp. size hole Ø		Core Ø of int. thread 7H*		Nom. Ø	Pitch P	Tapp. size hole Ø		Core Ø of int. thread 7H*		Nom. Ø	Pitch P	Tapp. size hole Ø		Core Ø of int. thread 7H*		
		min. mm	max. mm	min. mm	max. mm			min. mm	max. mm	min. mm	max. mm			min. mm	max. mm	min. mm	max. mm	
M 2	0.40	1.85	1.84	1.88	1.567	1.679	M 2.5 x 0.35	2.35	2.35	2.38	2.121	2.221	M 17 x 1.00	16.55	16.52	16.62	15.917	16.217
M 2.2	0.45	2.00	2.01	2.05	1.713	1.838	M 3 x 0.35	2.85	2.85	2.88	2.621	2.721	M 17 x 1.50	16.30	16.26	16.38	15.376	15.751
M 2.5	0.45	2.30	2.28	2.32	2.013	2.138	M 4 x 0.35	3.85	3.85	3.88	3.621	3.721	M 18 x 1.00	17.55	17.52	17.62	16.917	17.217
M 3	0.50	2.80	2.78	2.85	2.459	2.639	M 4 x 0.50	3.80	3.78	3.83	3.459	3.639	M 18 x 1.50	17.30	17.26	17.38	16.376	16.751
M 3.5	0.60	3.25	3.23	3.30	2.850	3.050	M 5 x 0.50	4.80	4.78	4.83	4.459	4.639	M 18 x 2.00	17.10	17.05	17.20	15.835	16.310
M 4	0.70	3.70	3.68	3.76	3.242	3.466	M 5.5 x 0.50	5.30	5.28	5.33	4.959	5.139	M 20 x 1.00	19.55	19.52	19.62	18.917	19.217
M 4.5	0.75	4.20					M 6 x 0.75	5.65	5.62	5.70	5.188	5.424	M 20 x 1.50	19.30	19.26	19.38	18.376	19.751
M 5	0.80	4.65	4.62	4.71	4.134	4.384	M 7 x 0.75	6.65	6.62	6.70	6.188	6.424	M 24 x 1.00	23.55	23.52	23.62	22.917	23.217
M 6	1.00	5.55	5.52	5.62	4.917	5.217	M 8 x 0.75	7.65	7.62	7.70	7.188	7.424	M 24 x 1.50	23.30	23.26	23.38	22.376	22.751
M 7	1.00	6.55	6.52	6.62	5.917	6.217	M 8 x 1.00	7.55	7.52	7.62	6.917	7.217	M 24 x 2.00	23.10	23.05	23.20	21.835	22.310
M 8	1.25	7.40	7.36	7.47	6.647	6.982	M 9 x 0.75	8.65	8.62	8.70	8.188	8.424	M 27 x 1.50	26.30	26.26	26.38	25.376	25.751
M 9	1.25	8.40	8.36	8.47	7.647	7.982	M 9 x 1.00	8.55	8.52	8.62	7.917	8.217	M 30 x 1.50	29.30	29.26	29.38	28.376	28.751
M 10	1.50	9.30	9.26	9.38	8.376	8.751	M 10 x 0.75	9.65	9.62	9.70	9.188	9.424	M 33 x 1.50	32.30	32.26	32.38	31.376	31.751
M 11	1.50	10.30	10.26	10.38	9.376	9.751	M 10 x 1.00	9.55	9.52	9.62	8.917	9.217	M 36 x 1.50	35.30	35.26	35.38	34.376	34.751
M 12	1.75	11.20	11.15	11.29	10.106	10.531	M 10 x 1.25	9.40	9.36	9.47	8.647	8.982	M 39 x 1.50	38.30	38.26	38.38	37.376	37.751
M 14	2.00	13.10	13.05	13.20	11.835	12.310	M 11 x 0.75	10.65	10.62	10.70	10.188	10.424	M 42 x 1.50	41.30	41.26	41.38	40.376	40.751
M 16	2.00	15.10	15.05	15.20	13.835	14.310	M 11 x 1.00	10.55	10.52	10.62	9.917	10.217						
M 18	2.50	16.90	16.83	17.02	15.294	15.854	M 12 x 1.00	11.55	11.52	11.62	10.917	11.217						
M 20	2.50	18.90	18.83	19.02	17.294	17.854	M 12 x 1.25	11.40	11.36	11.47	10.647	10.982						
M 22	2.50	20.90	20.83	21.02	19.294	19.854	M 12 x 1.50	11.30	11.26	11.38	10.376	10.751						
M 24	3.00	22.70	22.62	22.80	20.752	21.382	M 14 x 1.00	13.55	13.52	13.62	12.917	13.217						
M 27	3.00	25.70	25.62	25.80	23.752	24.382	M 14 x 1.25	13.40	13.36	13.47	12.647	12.982						
M 30	3.50	28.50	28.40	28.60	26.211	26.921	M 14 x 1.50	13.30	13.26	13.38	12.376	12.751						
M 33	3.50	31.50	31.40	31.60	29.211	29.921	M 15 x 1.00	14.55	14.52	14.62	13.917	14.217						
M 36	4.00	34.30	34.17	34.40	31.670	32.420	M 15 x 1.50	14.30	14.26	14.38	13.376	13.751						
M 39	4.00	37.30	37.17	37.40	34.670	35.420	M 16 x 1.00	15.55	15.52	15.62	14.917	15.217						
M 42	4.50	40.10	39.95	40.20	37.129	37.979	M 16 x 1.50	15.30	15.26	15.38	14.376	14.751						

* M 2 up to M 2.5 tapping size hole of internal thread 6H

* M 2.5 x 0.35 up to M 4 x 0.35 tapping size hole of internal thread 6H

Tapping size hole diameter tolerance zone for thread forming (to DIN 13, section 50)

Due to the tensile strength it is not necessary to adhere to the tapping size hole diameter tolerance class 6H; tolerance class 7H satisfies the requirement that the flank coverage of external and internal threads should not fall below $0.32 \times P$. In addition, formed threads generally possess a higher tensile strength in comparison to cut threads thanks to an uninterrupted grain flow and subsequent work hardening.



Recommended tapping size holes for thread forming

UNC threads ASME B1.1						UNF threads ASME B1.1						BSP threads DIN EN ISO 228-1								
Nom. Ø	Thre- ad per inch	Tapp. size hole Ø mm	Tapp. size hole Ø		Core Ø of int. thread 2B		Nom. Ø	Thre- ad per inch	Tapp. size hole Ø mm	Tapp. size hole Ø		Core Ø of int. thread 2B		Nom. Ø	Thre- ad per inch	Tapp. size hole Ø mm	Tapp. size hole Ø		Core Ø of int. thread	
			min. mm	max. mm	min. mm	max. mm				min. mm	max. mm	min. mm	max. mm				min. mm	max. mm		
No. 1 - 64		1.68	1.67	1.70	1.425	1.580	No. 1 - 72		1.70	1.69	1.72	1.473	1.610	G 1/16	28	7.30	7.28	7.35	6.561	6.843
No. 2 - 56		1.98	1.97	2.01	1.694	1.872	No. 2 - 64		2.00	1.99	2.03	1.755	1.910	G 1/8	28	9.30	9.28	9.35	8.566	8.848
No. 3 - 48		2.28	2.27	2.32	1.941	2.146	No. 3 - 56		2.30	2.29	2.34	2.024	2.197	G 1/4	19	12.50	12.48	12.55	11.445	11.890
No. 4 - 40		2.55	2.54	2.59	2.157	2.385	No. 4 - 48		2.60	2.59	2.63	2.271	2.459	G 3/8	19	16.00	15.98	16.05	14.950	15.395
No. 5 - 40		2.90	2.89	2.94	2.487	2.698	No. 5 - 44		2.90	2.89	2.93	2.550	2.741	G 1/2	14	20.00	19.98	20.12	18.631	19.172
No. 6 - 32		3.15	3.14	3.19	2.642	2.896	No. 6 - 40		3.20	3.19	3.24	2.819	3.023	G 5/8	14	22.00	21.98	22.12	20.587	21.128
No. 8 - 32		3.80	3.78	3.82	3.302	3.531	No. 8 - 36		3.85	3.83	3.88	3.404	3.607	G 3/4	14	25.50	25.48	25.62	24.117	24.658
No.10 - 24		4.35	4.33	4.39	3.683	3.937	No.10 - 32		4.45	4.43	4.49	3.962	4.166	G 7/8	14	29.25	29.23	29.37	27.877	28.418
No.12 - 24		5.00	4.97	5.03	4.343	4.597	No.12 - 28		5.10	5.07	5.13	4.496	4.724	G 1	11	32.00	31.98	32.15	30.291	30.931
1/4 - 20		5.75	5.72	5.80	4.978	5.258	1/4 - 28		5.95	5.92	5.99	5.359	5.588	G 1 1/4	11	40.75	40.70	40.85	38.952	39.592
5/16 - 18		7.30	7.26	7.37	6.401	6.731	5/16 - 24		7.45	7.42	7.50	6.782	7.036							
3/8 - 16		8.80	8.77	8.88	7.798	8.153	3/8 - 24		9.05	9.02	9.10	8.838	8.636							
7/16 - 14		10.30	10.27	10.37	9.144	9.550	7/16 - 20		10.55	10.48	10.58	9.728	10.033							
1/2 - 13		11.80	11.77	11.88	10.592	11.024	1/2 - 20		12.10	12.08	12.18	11.328	11.608							
9/16 - 12		13.30	13.28	13.39	11.989	12.446	9/16 - 18		13.65	13.61	13.72	12.751	13.081							
5/8 - 11		14.80	14.78	14.90	13.386	13.868	5/8 - 18		15.25	15.21	15.32	14.351	14.681							
3/4 - 10		17.90	17.85	17.97	16.307	16.840	3/4 - 16		18.35	18.30	18.41	17.323	17.678							
7/8 - 9		21.00	20.95	21.10	19.177	19.761	7/8 - 14		21.40	21.35	21.49	20.269	20.650							
1 - 8		24.00	23.95	24.12	21.971	22.606	1 - 12		24.45	24.40	24.54	23.114	23.571							



General information for tapping

Definitions and angles, centres and flute forms

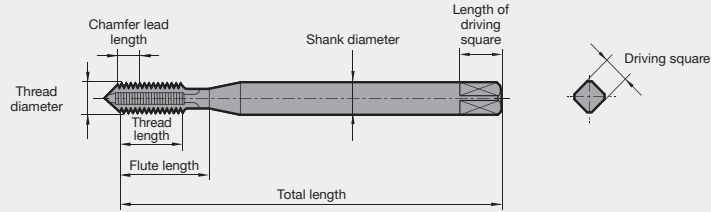

Try square
Spiral point angle
Clearance angle
Rake angle

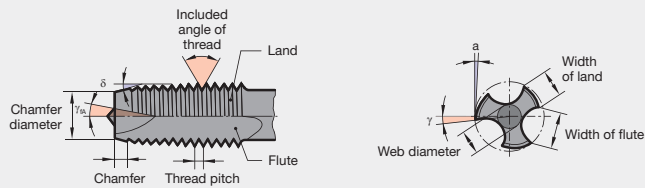

Flute forms



straight fluted, form C
without spiral point



Helix angle **15°**



straight fluted, form B
with spiral point



Helix angle **40°**

Types of centres (standard, to DIN 2197/DIN 2175)

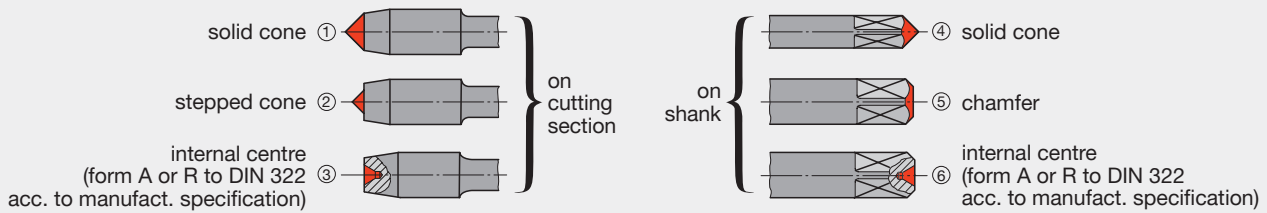

Thread diameter range mm	Centre on cutting section		Centre on shank
	with chamfer forms A, C, D, E	with chamfer form B	
≤ 4.2	①	①	④⑤⑥
> 4.2 ... 5.6	①②	①	④⑤⑥
> 5.6 ... 10.0	①②③	①②③	④⑤⑥
> 10.0	③	③	⑥

Coolant duct geometries



axial coolant supply
with axial coolant
duct exit



axial coolant supply
with radial coolant duct exit
in the flutes at the chamfer



General information for tapping

Chamfer forms – selection and application

When cutting internal threads, all the machining is carried out by the cutting teeth of the chamfer. Therefore, a decision on the best type of chamfer form has to be carefully made as both tool life and quality of thread are thereby greatly affected.

Generally speaking, the form and length of chamfer depend on the type of hole to be tapped. The tapping of through holes does not normally give rise to any difficulties whereas the production of blind holes can create certain problems associated with the need to evacuate swarf in the reverse direction to the feed, i.e. up to the flutes of the tap and then cut off such swarf when the tap is reversed out of the hole.

The length of chamfer is determined by taking into account various conflicting factors. To avoid overloading, premature bluntness and oversize threads the number of chamfer cutting threads must not be kept too low. A too long chamfer lead, however, increases the torque and thus the danger of breakage. The spiral point with form B ensures a chip removal always in the direction of feed.

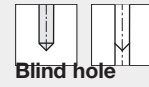

Chamfer forms to DIN 2197

Form A

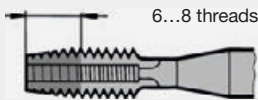

long, 6 - 8 threads for short through holes

Form B



medium, 3.5 - 5.5 threads, with spiral point, for all through holes and deep tapping holes in medium and long-chipping materials

Form C

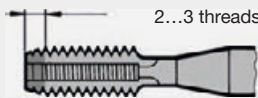

short, 2 - 3 threads for blind holes and generally for aluminium, grey cast iron and brass

Form D



medium, 3.5 - 5 threads for short through holes

Form E

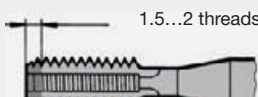

very short, 1.5 - 2 threads, for blind holes with little run-out depth

Form F



extremely short, 1 - 1.5 threads, for blind holes with little run-out depth. Avoid use if possible.



General information for tapping

Taps for ISO metric threads DIN EN 22857 (extract)

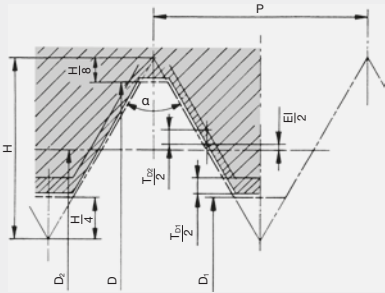

Profile of the internal thread

Basic profile:

- D Major diameter
- D₁ Nominal diameter of tapping size hole
- D₂ Basic pitch diameter
- P Pitch of diameter
- α Included angle of thread
- H Height of peak to peak thread profile
- El basic deviation of pitch, zero with tolerance zone H, positive with tolerance zone G

Tolerances:

- T_{D1} Tolerance on tapping size hole diameter
- T_{D2} Tolerance on tap pitch diameter

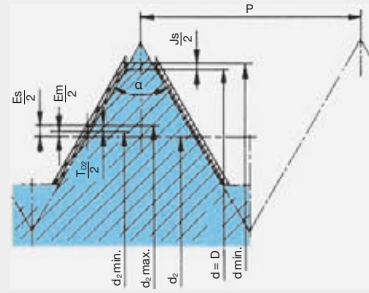

Profile of the tap

Basic profile:

- d=D Major diameter
- d min. Permissible min. tap major diameter
- Js Minimum clearance on major diameter
- d₂=D₂ Basic pitch diameter
- d₂ min. Minimum tap pitch diameter
- d₂ max. Maximum tap pitch diameter
- Es Upper deviation of pitch diameter
- Em Lower deviation of pitch diameter

Tolerances:

- T_{d2} Tolerance on tap pitch diameter

With the aim of unifying threads on an international basis, the ISO thread was brought out and has in the meantime been accepted by all concerned. Nowadays the ISO metric thread is the most common type. As you can see, our tap program demonstrates this fact in the clearest possible way.

Tolerance qualities (figure identification)

Tolerance qualities of external threads are defined by figures 3 to 9, those of internal threads by figures 4 to 8. 3 stands for the narrowest and 9 for the widest tolerance.

Tolerance positions (letter identification)

ISO metric internal threads are identified by capital letters A to H, ISO metric external threads by small letters a to h. Tolerance zones A to G have positive and a to g negative basic pitch deviations in contrast to the tolerance zones H and h which commence at zero. Generally, tolerance zones H and g are used. For threads destined for surface treatment tolerance zones G and e are applied.

When manufacturing ISO external threads the deviations that are determined for the major diameter with regard to the tolerance zones a to g have to be taken into account.

Tolerance zones (internal thread)/

Tolerance classes (tap)

Quality and position of tolerance determine the tolerance zone, which is identified by the appropriate figures and letters. The abbreviation for the tolerance class of tap corresponds to the tolerance zone of the internal thread for which the tap is used in most cases. Therefore, it is not identical with the tolerance zone of the cut internal thread in every application. Taps with deviating tolerances according to DIN 802 part 1 will be given additional marking "X" (6 HX, 6 GX).

We recommend the application of taps in accordance with the adjacent table:

Tolerance zone/tolerance class allocation

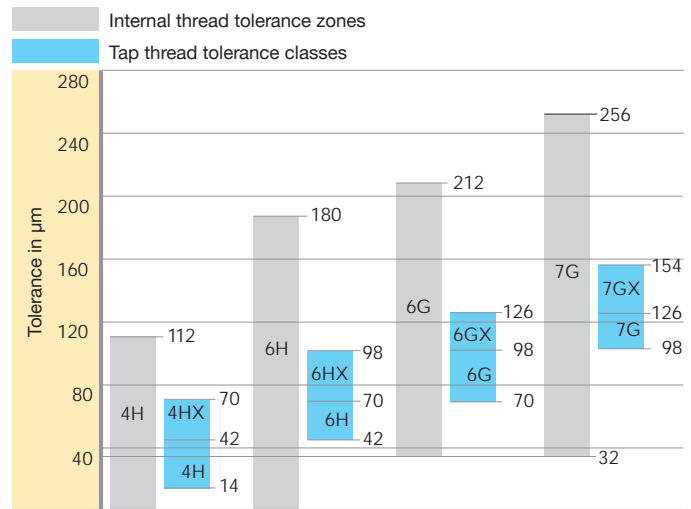

DIN EN 22857		Tolerance zone of internal thread to be cut				DIN 802 part 1 (withdrawn)
Application class of tap	Reference	4H	5H	6H	6G	7G
Class 1	ISO 1	4H	5H			4H
Class 2	ISO 2			6H		6H
Class 3	ISO 3				6G	6G
-	-					7G

* The tolerance of the 3 application classes is calculated in accordance to the following data dependent on one tolerance unit t the value of which corresponds to the value of the basic pitch diameter T_{D2} in tolerance class 5 of the internal thread (polished to a pitch of 0.2mm):
t = T_{D2} Tolerance class 5 of internal thread



General information for tapping

OH limits for JIS taps

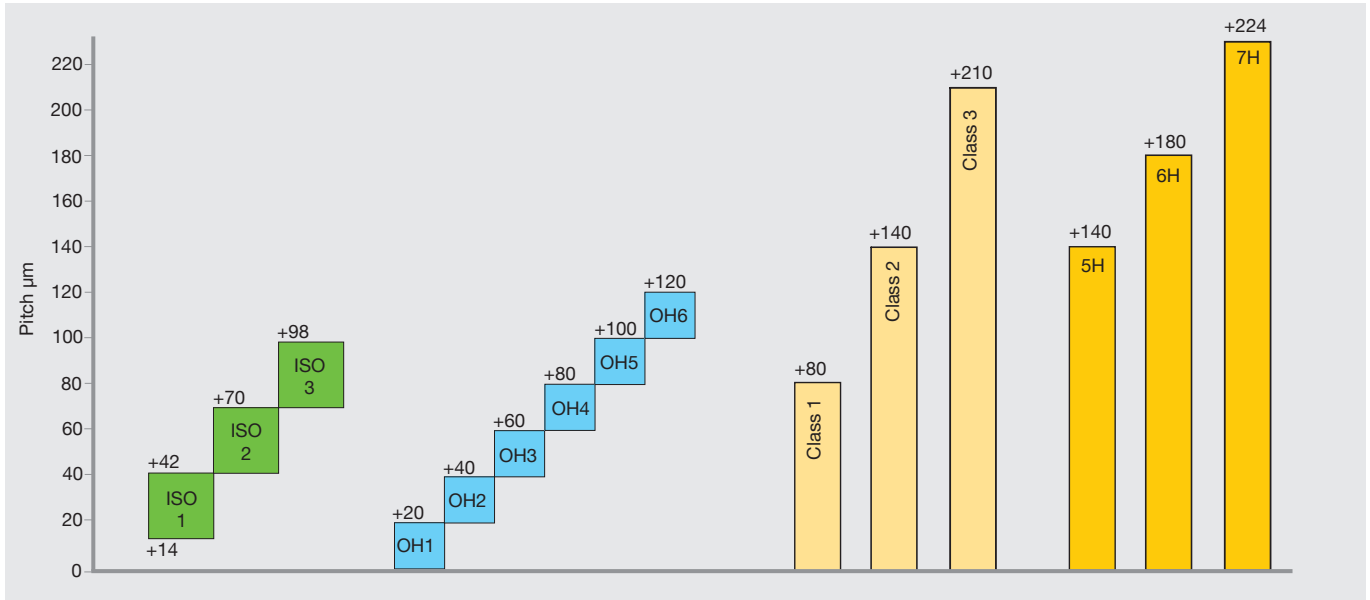

RH limits for JIS fluteless taps

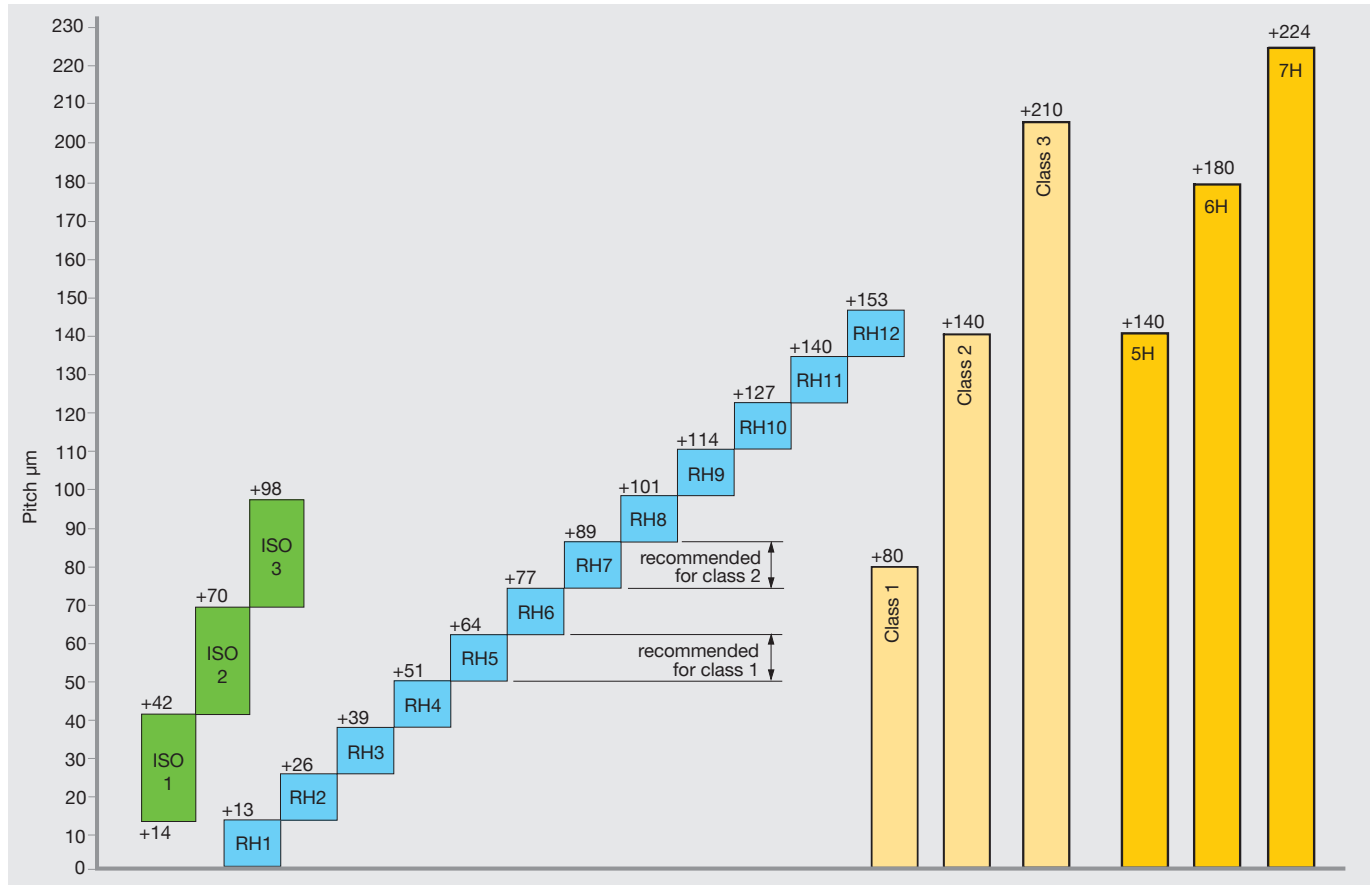

upper limit: $0,0127 \times n$
 lower limit: $0,0127 \times n - 0,0127$
 unit: $\text{mm} / n = \text{RH number}$



General information for tapping

Taps for ISO metric threads DIN EN 22857 (extract)

Thread clearances and fits

Fits between internal and external threads are separated by a diagonal stroke, as for example 6H/6g (internal/external thread). The fit has to be selected in conjunction with the appropriate thread connection.

The tolerance zones of the tolerance classes fine, medium and coarse are allocated to three screw-in lengths short S), normal (N) and long (L). Generally, the following rules apply for selecting a tolerance class:

Fine tolerance zone (S):

For precision threads, when only a small variation in the fit is permitted.

Medium tolerance zone (N):

General application

Coarse tolerance zone (L):

There are no special precision requirements and in cases where production difficulties may occur, e.g. thread production in hotrolled rods, deep blind holes or plastic components.

Screw-in lengths

The quality of thread connection is also affected by the screw-in length. The ISO tolerance system was, especially as regards the pitch diameter, divided into three groups, i.e.

S	(Short)	= short screw-in length
N	(Normal)	= normal screw-in length
L	(Long)	= long screw-in length

The following fit should be selected for normal screw-in length N: To ensure a tighter fit of thread connections, we recommend for short screw-in lengths a narrower fit. As far as long screw-in lengths are concerned, fits with a larger tolerance must be used to compensate for pitch deviations.

Thread fits with varying flank clearance

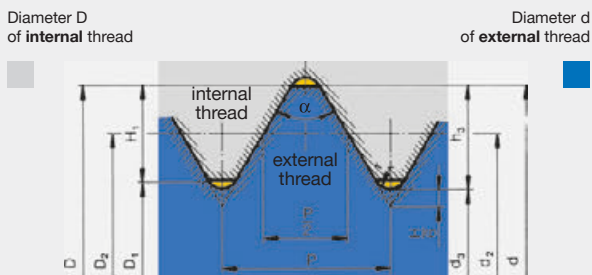

Fine thread fit without flank clearance (H/h-fit)

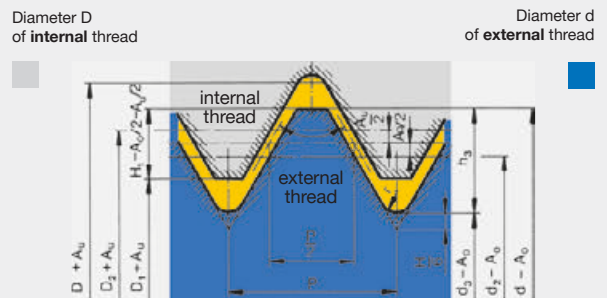

Coarse thread fit with wide flank clearance (G/g or G/e-fit) in external and internal thread.

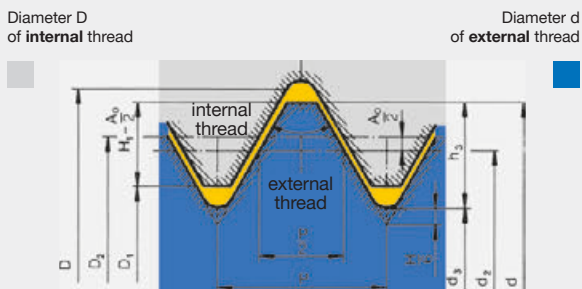



Medium thread fit with close flank clearance (H/h or H/e-fit) by basic deviation of external thread

Explanation of symbols

D	=	nominal Ø of internal thread
D ₁	=	tapping size hole Ø of internal thread
D ₂	=	basic pitch Ø of internal thread
d	=	nominal Ø of external thread
d ₂	=	basic pitch Ø of external thread
d ₃	=	tapping size hole Ø of external thread
P	=	pitch
a	=	included angle of thread
H	=	height of peak to peak thread profile
A _u	=	upper tolerance limit
A _l	=	lower tolerance limit



Application problems with new taps

Problem	Possible causes	Solution
<p>1 Thread produced is too large</p> 	<ul style="list-style-type: none"> ■ incorrect tap, tap geometry not suitable for the application ■ tapping size hole too small ■ alignment error of tapping size hole or position ■ machine spindle axially restricted ■ cold welding at the flank of the tap ■ lead of tap unsatisfactory due to insufficient thread depth ■ cutting speed too high ■ lubrication or coolant supply insufficient ■ tolerance specification on tap does not correspond to specifications on drawing and/or thread gauge 	<ul style="list-style-type: none"> ■ apply correct tap for the material to be machined ■ observe tapping size hole table in the technical section. Note different tapping size hole diameters for fluteless taps ■ - check for correct tool clamping ■ - apply floating tap holder ■ - check core drill ■ - use mechanical feed ■ - apply tension/compression tap chuck ■ - apply new tap ■ - apply coated tap ■ - optimise lubrication ■ - tap with forced feed ■ - apply tap with modified lead ■ - reduce cutting speed ■ - improve lubrication ■ ensure sufficient and suitable coolant supply and check concentration ■ apply correct tap for required tolerances
<p>2 Thread axially miscut</p> 	<ul style="list-style-type: none"> ■ spiral-fluted taps, corresponding to our design, are applied with too much pressure for initial tapping ■ initial tapping pressure too low for taps with spiral point corresponding to our form "B" 	<ul style="list-style-type: none"> ■ with spiral-fluted taps only light pressure required for initial tapping. The tap should immediately be applied within the tension/compression range ■ taps with spiral point or left hand spiral require higher axial pressure. Ensure tap operates within the tension/compression range
<p>3 Thread produced is too small</p> 	<ul style="list-style-type: none"> ■ tolerance specification on tap does not correspond to specifications on drawing and/or thread gauge ■ incorrect tap ■ tap does not cut accurately (thread plug gauge) ■ machine spindle is axially too rigid 	<ul style="list-style-type: none"> ■ apply correct tap for required tolerance ■ apply correct tap for the material to be machined ■ avoid strong axial forces during the cutting process ■ apply tension/compression chuck

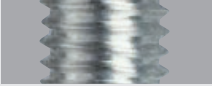
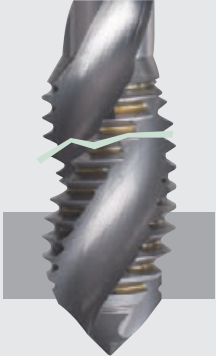

Application problems with new taps

Problem	Possible causes	Solution
<p>4 Thread surface not according to requirements</p> 	<ul style="list-style-type: none"> ■ cutting edge geometry not suitable for the application ■ cutting speed too high ■ insufficient coolant (concentration and supply) ■ chip congestion ■ tapping size hole too small ■ with tough, hard materials loading on tool too much or pitch too steep ■ built-up edge ■ cold welding 	<ul style="list-style-type: none"> ■ apply "correct" tap for the material to be machined ■ - reduce cutting speed ■ - optimise lubrication ■ ensure suitable coolant and sufficient volume ■ apply suitable tap type ■ observe tapping size hole diameter specifications to DIN 336 or respective standards. Observe table for fluteless taps ■ apply hand tap sets ■ apply coated tap ■ improve coolant supply
<p>5 Tool life insufficient</p>	<ul style="list-style-type: none"> ■ surface hardening of tapping size hole ■ reasons listed under: "thread surface not according to requirements" ■ chip congestion 	<ul style="list-style-type: none"> ■ - check drill (cutting edge) for wear ■ - heat or surface treatment following thread production ■ reasons listed under: thread surface "not according to requirements" ■ apply correct tap
<p>6 Tool breakage during advance or return</p> 	<ul style="list-style-type: none"> ■ tapping size hole too small ■ teeth of chamfer lead overloaded ■ tap hits bottom of tapping size hole ■ - lack of or incorrect chamfer of tapping size hole ■ - positional or angle error of tapping size hole ■ - tool hardness not suitable for the application ■ - cutting edge geometry not suitable for the application 	<ul style="list-style-type: none"> ■ observe tapping size hole dia. acc. to DIN 336 or respective standards ■ - longer chamfer lead (blind or through hole) ■ - increase no. of teeth of chamfer lead by increasing no. of flutes ■ - apply tap sets ■ - check hole depth ■ - apply tension/compression tap chuck ■ - correct chamfer angle of tapping size hole ■ - ensure correct tool clamping ■ - apply floating tap holder ■ - check core drill ■ apply suitable tap for the individual application



Application problems with reground taps

Problem	Possible causes	Solution
7 Thread produced is too large	<ul style="list-style-type: none">■ burrs■ cutting edge geometry (chamfer lead, rake-, chamfer-, spiral point angle) not retained	<ul style="list-style-type: none">■ remove burrs■ - observe technical specifications when regrinding■ - observe regrinding instruction
8 Thread produced is too small	<ul style="list-style-type: none">■ worn section has not been reground correctly■ tap too small due to no. of regrinds	<ul style="list-style-type: none">■ - regrind again or apply new tool■ - observe max. regrinding limits■ - max. regrinding limit reached■ - apply new tap
9 Thread produced not according to requirements	<ul style="list-style-type: none">■ burrs■ cutting edge geometry (chamfer lead, rake-, chamfer-, spiral point angle) not retained■ peak-to-valley height of the reground tap too large■ cold welding at the flanks	<ul style="list-style-type: none">■ remove burrs■ - observe technical specifications when regrinding■ - observe regrinding instruction■ - regrind again or apply new tool■ - observe max. regrinding limits■ remove cold welding marks
10 Tool life insufficient	<ul style="list-style-type: none">■ cutting edge geometry (chamfer lead, rake-, chamfer-, spiral point angle) not retained■ loss of tap hardness due to heat development during the regrinding process■ loss of coating	<ul style="list-style-type: none">■ - regrind again or apply new tool■ - observe max. regrinding limits■ - check quality of grinding wheel■ - check coolant supply■ - recoat■ - check coating of the material to be machined



General information thread forming

Fluteless taps are used for the forming of internal threads without chip removal. In contrast to conventional tapping where material is cut from the workpiece, thread forming is a pressure deformation process without chip removal for the production of internal threads. During the process the material is cold formed without interrupting the grain flow.

According to DIN 8583, thread forming is described as “pressing the thread into the workpiece with a tool possessing a spiral working area”. The spiral threaded, polygonal portion of the fluteless tap is “screwed” into the pre-drilled workpiece with an appropriate constant feed rate equal to the thread pitch. Hereby the thread profile is pressed gradually via the forming lead into the material of the workpiece so to speak. Subsequently, the pressure in the deformation zone exceeds the compression limit, the workpiece becomes ductile and is deformed. The material yields radially, “flows” along the thread profile in the unoccupied base of the tool and forms the minor diameter of the internal thread. The flow process creates the process specific form pockets (claws).

The tapping size hole diameter is heavily dependent on the formability of the material, the workpiece geometry and the required effective depth of the thread. In comparison to conventional tapping, a larger diameter tapping size hole should be selected. With a larger diameter tapping size hole the load on the tool is reduced whilst increasing the tool life. Thanks to the uninterrupted grain flow, the loading capacity of the thread remains sufficient with a 50% effective thread depth.

The partially formed crests of the thread with decreasing effective thread depth are a typical characteristic of threads produced by the thread forming process. With the flanks of the thread fully formed, they have no influence on the tensile strength of the thread. If necessary, the required deformation level of the thread should be determined by performing a test.

Lubrication is of significant importance. The lubrication prevents material from building up on the thread flanks and ensures that the necessary torque for the forming process is not too high. Therefore, under no circumstances should there ever be a break-down in lubrication! Preference should be given to lubricants such as cooling agents of oils containing graphite such as those used in rolling processes. Always follow the rule: “The better the lubrication the easier the thread forming process!”

It offers the following advantages

- no chip formation
- one tool for the production of threads in through and blind holes
- application in wide range of materials
- no cutting errors
- pitch and angle of thread errors that can occur with thread cutting are eliminated
- internal threads produced by thread forming possess a higher tensile strength particularly at the thread flanks thanks to the so-called “uninterrupted grain flow” and the cold forming process
- the surface of the thread is improved
- fluteless taps can be applied at higher speeds because the formability of many materials increases with the forming speed. This does not have a negative effect on the tool life.
- reduced danger of breakage through rigid design

Process

The production of internal threads without chip removal (thread forming) in comparison to conventional tapping

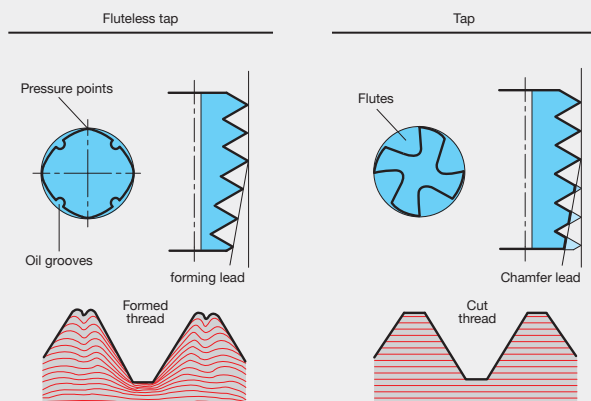

Flow characteristics of the material during thread forming and the deformation process

- D = nominal \varnothing
- D₂ = flank \varnothing
- D_k = hole \varnothing
- H = profile height
- P = thread pitch
- A = form pocket (claw)
- finished internal thread

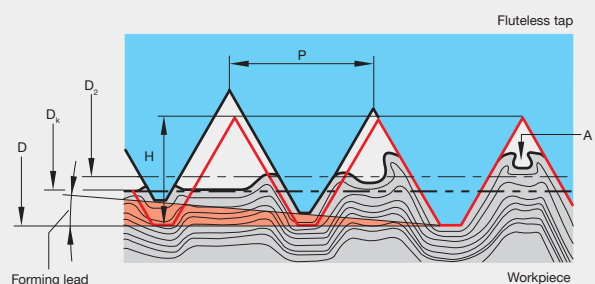



General information thread forming

Conventional fluteless taps, produced by a grinding process only, show traces of microscopic, very fine grinding marks on the surface of the tool. This also applies to the threaded portion of the tool required to perform the thread forming operation.

This surface topography (structure) has a negative effect on the friction between the tool and the material to be re-formed as well as on the herewith associated heat development, on the necessary torque and last but not least on the wear of the pressure points of the fluteless tap. In addition, the "grinding marks" encourage the build-up of the material to be re-formed in the thread flanks of the fluteless tap. This is also called cold welding.

Thanks to a special process to improve the surface topography (structure), Hartner's new fluteless taps no longer possess these "grinding marks". This has been confirmed in research and tool life studies in varying materials under production conditions.

For the user, a longer tool life and increased cutting speeds are the benefits of this special process. The tool life can be increased considerably depending on the material to be machined and the application conditions. A 100% increase in tool life is not unusual.

The improved surface topography is not only of benefit to tools with bright finish. Particularly coated tools also benefit from the new process. Outer contour and forming lead greatly determine the performance of the fluteless tap. Numerous tests have shown that fluteless taps with optimal pressure point geometry and quantity achieve increased tool life and dimensional accuracy.

Further improvements in quality are achieved when the fluteless tap is produced completely in one setting and with one grinding wheel - set-up with a special roll. Pitch errors between the thread crests and former lead transition area do not occur as with the conventional grinding process.

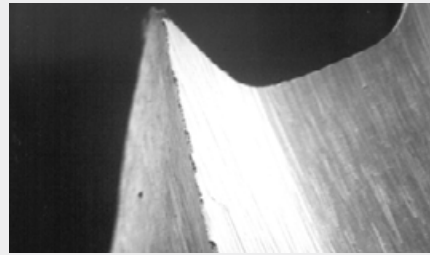

Tooth of a conventional fluteless tap

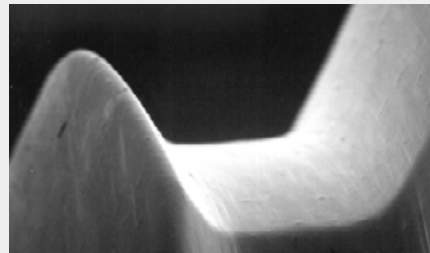

Optimised surface of a Hartner profile fluteless tap

Cross section of fluteless tap

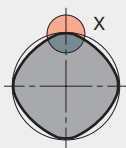

Detail x
D1 = flank diameter
D = nominal diameter

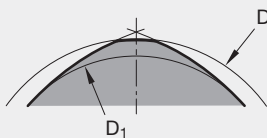

Operating principle

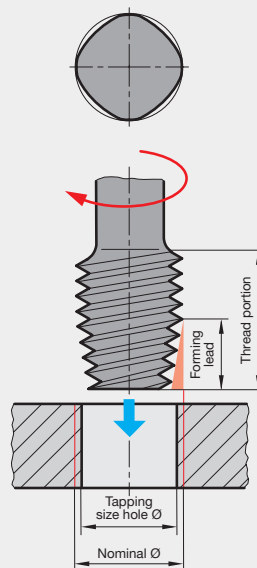

Types of tapping size hole

Fluteless taps without oil grooves for thread depth $\leq 1 \times D$



for thread depth $\geq 1 \times D$



Fluteless tap with oil grooves for all thread depths





General information thread forming

Definitions and angles, centres, thread tolerances and fits

Thread portion

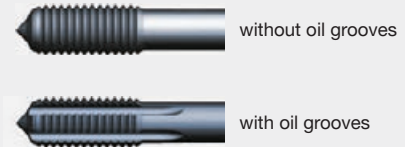
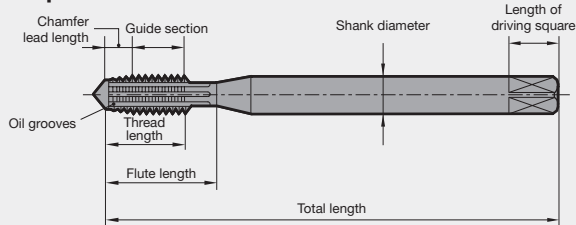

Types of centres (standard, to DIN 2197/DIN 2175)

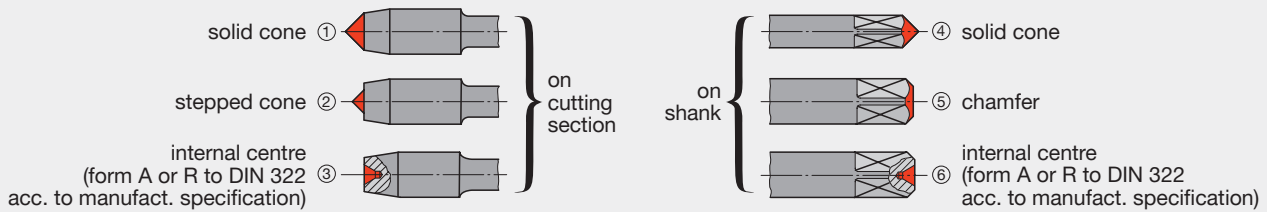

Thread diameter range mm	Centre on cutting section		Centre on shank
	with chamfer forms A, C, D, E	with chamfer form B	
≤ 4,2	1	1	4 5 6
> 4,2 ... 5,6	1 2	1	4 5 6
> 5,6 ... 10,0	1 2 3	1 2 3	4 5 6
> 10,0	3	3	6

Thread tolerances and fits

Fits between internal and external threads are separated by a diagonal stroke, as for example 6H/6g (internal/external). The fit has to be selected in conjunction with the appropriate thread connection.

The tolerance zones of the tolerance classes fine, medium and coarse are allocated to three screw-in lengths short (S), normal (N) and long (L). Generally, the following rules apply for selecting a tolerance class:

Fine tolerance zone (S):

For precision threads, when only a small variation in the fit is permitted.

Screw-in lengths

The quality of thread connection is also affected by the screw-in length. The ISO tolerance system was, especially as regards the pitch diameter, divided into three groups, i.e.

- S (Short) = short screw-in length
- N (Normal) = normal screw-in length
- L (Long) = long screw-in length

Medium tolerance zone (N):

General application

Coarse tolerance zone (L):

There are no special precision requirements and in cases where production difficulties may occur, e.g. thread production in hotrolled rods, deep blind holes or plastic components.

The following fit should be selected for normal screw-in length N: to ensure a tighter fit of thread connections, we recommend for short screw-in lengths a narrower fit.



General information thread forming

Definitions and angles, centres, thread tolerances and fits

Thread fit with varying flank clearance

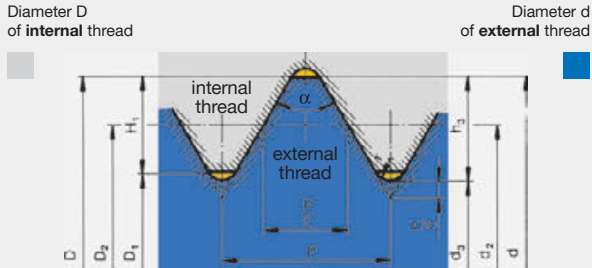

Fine thread fit without flank clearance (H/h-fit)

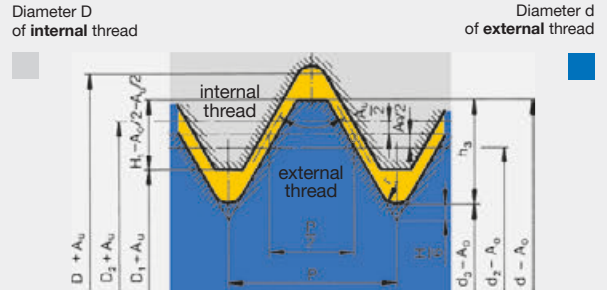

Coarse thread fit with wide flank clearance (G/g or G/e-fit) in external and internal thread.

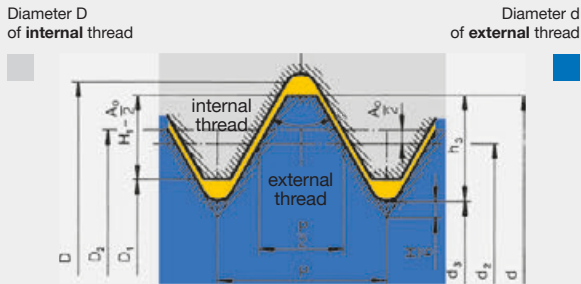

Medium thread fit with close flank clearance (H/h or H/e-fit) by basic deviation of external thread

Explanation of symbols

- D = \varnothing nominal of internal thread
- D₁ = tapping size hole \varnothing of internal thread
- D₂ = basic pitch \varnothing of internal thread
- d = \varnothing nominal of external thread
- d₂ = basic pitch \varnothing of external thread
- d₃ = tapping size hole \varnothing of external thread
- P = pitch
- a = included angle of thread
- H = height of peak to peak thread profile
- A_s = upper tolerance limit
- A_i = lower tolerance limit

Tapping size hole diameter

With fluteless tapping, the tapping size hole diameter influences the distinction of the formed thread. A too small tapping size hole diameter results in an over-forming of the thread which must definitely be prevented because this can lead to tool breakage. A too large tapping size hole is acceptable with certain tolerances because formed threads have a sufficient loading capacity from a 50 % bearing depth.



- Tapping size hole diameter is too large:
- thread not formed
 - large form pocket (claw)
 - height of profile too low



- Optimal tapping size hole diameter:
- thread fully formed
 - small form pocket (claw)
 - optimal height of profile



- Tapping size hole too small:
- thread over-formed
 - no form pocket (claw)
 - profile too high

Cooling lubricants with fluteless taps

With fluteless taps the main task of the coolant is lubrication. The better the lubrication with the maximum concentration, the longer the tool life.

There are two different types of lubricant:

Oil based lubricants

These are mineral oils with the best lubricating characteristics. They reduce friction and achieve optimal life.

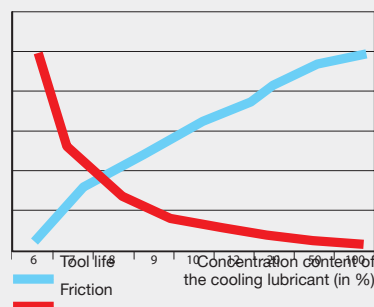

Soluble lubricants

These soluble lubricants are a concentrate thinned to an emulsion prior to the use with water. The concentration must not be below 6 %. A content more than 12 % is ideal in order to achieve a long life thanks to a good lubrication effect.



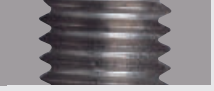
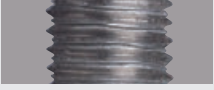

Application problems with new fluteless taps

Problem	Possible causes	Solution
<p>1 Thread produced is too large</p> 	<ul style="list-style-type: none"> ■ insufficient tool clamping ■ fluteless tap with short cutting portion 	<ul style="list-style-type: none"> ■ apply synchro chuck ■ apply fluteless tap with long cutting portion
<p>2 Thread produced is too small</p> 	<ul style="list-style-type: none"> ■ tapping size hole diameter too large 	<ul style="list-style-type: none"> ■ select correct tapping size hole diameter according to table
<p>3 Thread overformed</p> 	<ul style="list-style-type: none"> ■ tapping size hole diameter too small 	<ul style="list-style-type: none"> ■ select correct tapping size hole diameter according to table
<p>4 Poor surface finish</p> 	<ul style="list-style-type: none"> ■ cold welding on the tool ■ lubricant with too little oil content 	<ul style="list-style-type: none"> ■ increase oil content in lubricant or apply neat oil ■ increase oil content in lubricant or apply neat oil
<p>5 Tool life insufficient</p>	<ul style="list-style-type: none"> ■ lubricant with too little oil content ■ tapping size hole diameter too small ■ cutting speed too high ■ lubricant soiled 	<ul style="list-style-type: none"> ■ increase oil content in lubricant or apply neat oil ■ select correct tapping size hole diameter according to table ■ adjust cutting speed ■ check filtration

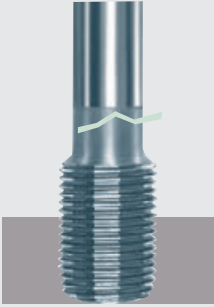

Application problems with new fluteless taps

Problem	Possible causes	Solution
<p>6 Tool breakage</p> 	<ul style="list-style-type: none">■ lubricant with too little oil content■ tapping size hole diameter too small■ incorrect tool clamping	<ul style="list-style-type: none">■ increase oil content in lubricant or apply neat oil■ select correct tapping size hole diameter according to table■ check tool clamping



Application recommendations

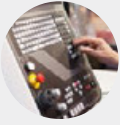

The cutting values shown below are standard values.
These values can be adapted upwards or downwards according to the specific application.
In case your specific material is not listed in the table below, please feel free to contact us.

- optimally suited
- partly suitable
- x not suitable

ISO	Material group	Hardness	Material example	Material no.
P	Structural and free cutting steels, heat-treatable steels unalloyed	< 800 N/mm ²	S235JR	1,0037
			C15	1,0401
			11SMnPb30	1,0718
	Free-cutting steels, unalloyed case hardened steels, nitriding steels	800 - 1000 N/mm ²	S355J2	1,0577
			C60	1,0601
			31CrMo12	1,8515
Alloyed heat-treatable steels, tool steels, high speed steels	800 - 1200 N/mm ²	42CrMo4	1,7225	
		36CrNiMo4	1,6511	
		X36CrMo17	1,2316	
		HS 6-5-2	1,3343	
M	Stainless steels, sulphured, austenitic	< 1000 N/mm ²	X5CrNi18-10	1,4301
			X6CrNiTi18-10	1,4571
			X8CrNiS18-9	1,4305
	Stainless- and acidresistant steels, martensitic	< 1000 N/mm ²	X17CrNi16-2	1,4057
			X90CrMoV18	1,4112
			X2CrTi12	1,4512
Duplex and Super Duplex	< 1300 N/mm ²	X2CrNiMoN22-5-3	1,4462	
		X2CrNiMoN25-7-4	1,441	
			X2CrNiMoCuWn25-7-4	1,4501
K	Cast Iron	300 HB	EN-GJL-150	0,6015
			EN-GJL-250	0,6025
			EN-GJL-300	0,603
	Spheroidal graphite iron and malleable cast iron	350 HB	EN-GJS-400-15	0,704
			EN-GJS-600-3	0,706
			EN-GJS-700-2	0,707
ADI, GGW	1000 N/mm ² 350 HB	EN-GJS1000-5		
		EN-GJV250		
			EN-GJV400	
N	Aluminium and wrought alloys	< 450 N/mm ²	Al99,5H	3,025
			AlMgSi1	3,2315
			AlZn4,5Mg	3,4335
	Aluminium cast alloys	< 600 N/mm ²	GD-ALSi5Cu1Mg	3,2134
			GD-ALSi8Cu3	3,2162
			G-ALSi9Mg	3,2373
			G-ALSi12	3,2581
	Magnesium alloys	< 500 N/mm ²	GDMgAl8Zn1	3,5812,08
			CuZn20	2,025
	Copper and copper alloys	long-chipping	CuZn37Pb0,5	2,0332
short-chipping			2,038	
			CuZn43Pb2	2,041
	Copper special alloys	< 1400 N/mm ²	Ampco	
	Plastics [Thermoplaste, Duroplaste]	long-chipping	PMMA, POM, PVC	
			short-chipping	
S	Titanium and titanium alloys	< 1200 N/mm ²	Titanium	3,7025
			TiAl5Sn2	3,7115
			TiAl6V4	3,7165
	Nickel, cobalt, iron alloys	< 1400 N/mm ²	Hasteloy C4	2,461
Inconel 718			2,4668	
			Nimonic	2,4634
H	High tensile steels, hardened steels	45 - 55 HRC	Hardox	
		55 - 62 HRC	PM30	



HARTNER

Application recommendations

_basic _{line}				-top _{line}		-top _{line}						_basic _{line}		-top _{line}			
HSS-E				HSS-E-PM		HSS-E-PM		HSS-E				Fluteless taps		Fluteless taps			
TG 100 U		TG 100 U		TG 100 T		TG 100 T		TG 100 AL		TG 100 GG		TG 300 T		Fluteless taps		Fluteless taps	
Suitability	V _c (m/min.)	Suitability	V _c (m/min.)	Suitability	V _c (m/min.)	Suitability	V _c (m/min.)	Suitability	V _c (m/min.)	Suitability	V _c (m/min.)	Suitability	V _c (m/min.)	Suitability	V _c (m/min.)	Suitability	V _c (m/min.)
••	10	••	12	••	20	••	23	x		x		x		••	20	••	25
••	8	••	10	••	15	••	18	x		x		••	15	••	15	••	25
•	6	•	8	••	10	••	14	x		x		••	12	•	8	••	15
•	6	•	8	••	12	••	15	x		x		x		••	6	••	15
x		x		••	10	••	13	x		x		x		•	4	••	10
x		x		••	6	••	9	x		x		x		•	4	••	6
•	10	•	12	•	15	•	18	x		••	20	••	30	x		x	
•	8	•	10	•	15	•	18	x		••	20	••	20	•	15	•	30
x		x		•	8	•	11	x		•	8	••	15	•	10	••	25
•	10	x		•	12	•	15	••	15	x		x		x		•	15
•	8	x		•	15	•	x	x		x		••	30	•	15	••	30
x		x		x		x	x	x		x		x		x		x	
•	10	x		•	12	•	x	••	15	x		x		•	15	•	30
x		x		x		x	x	x		•	4	•	6	x		x	
x		x		x		x	x	•	8	x		x		x		x	
x		x		•	3	•	4	x		x		x		x		••	8
x		x		•	2	•	3	x		x		x		x		••	8
x		x		x		x	x	x		x		x		x		x	
x		x		x		x	x	x		x		x		x		x	

THE HARTNER PROGRAMME



▼ DRILLING TOOLS



▼ MULTISTEP



▼ COUNTERSINKS



▼ MICRO-PRECISION DRILLS



▼ THREADING TOOLS



▼ TS-DRILLS



▼ THREAD MILLING CUTTERS



▼ SOLID CARBIDE MILLING CUTTERS



▼ REAMERS



▼ MULTIPLEX



▼ MULTIPLEX HPC



▼ TM VENDING MACHINES

HARTNER GMBH

P.O. Box 10 04 27 | 72425 Albstadt | Germany
Tel. +49 74 31 125-0 | Fax +49 74 31 125-21 547

www.hartner.de

No liability can be accepted for printing errors or technical changes of any kind.
Our Conditions of Sale and Terms of Payment apply. Available on request.

148 599/25004-II-10 | Printed in Germany | 2025